

39 Bethune Street New York, NY 10014

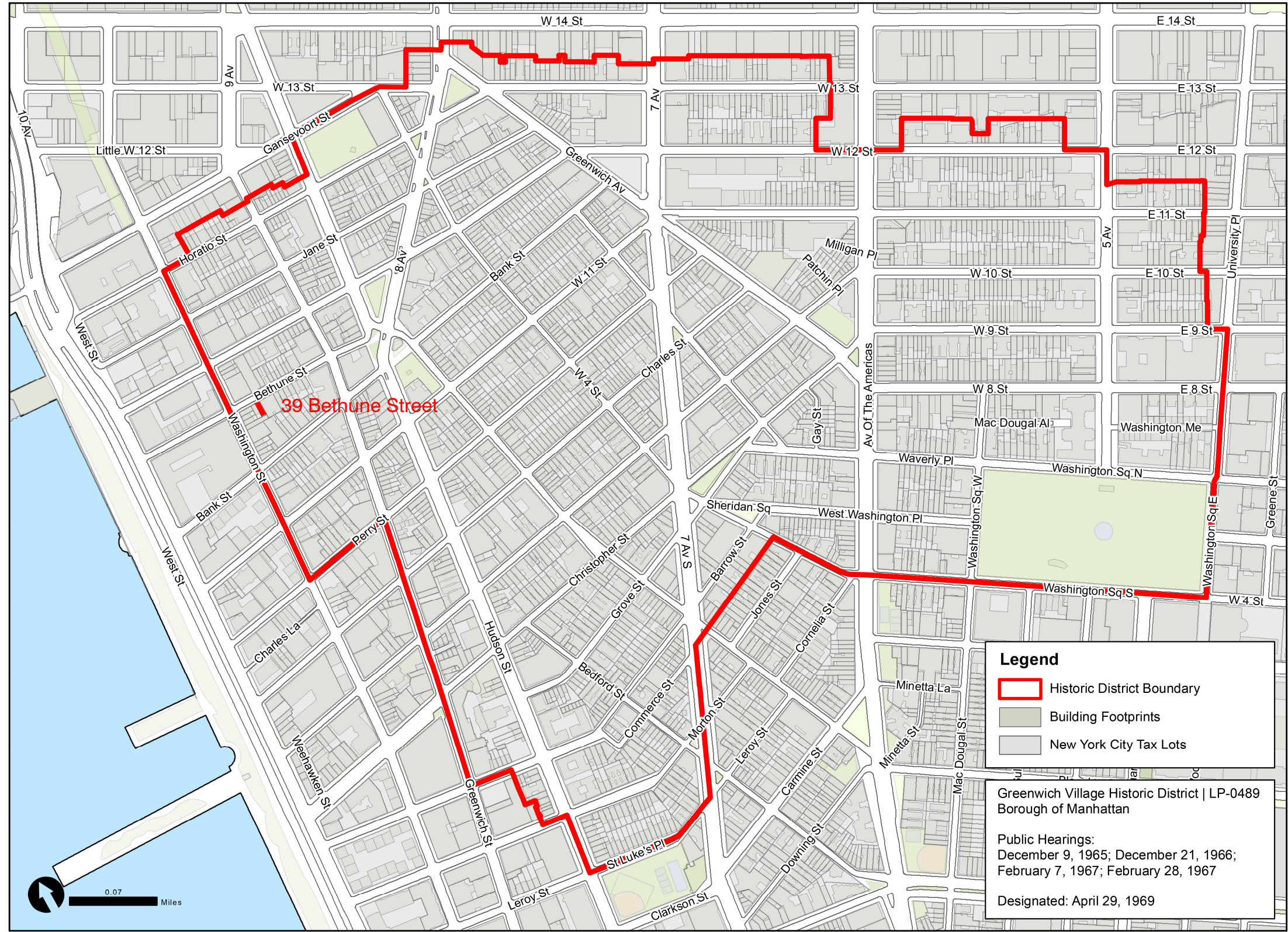



Graphic Source: Map PLUTO, Edition 18v1, Author: New York City Landmarks Preservation Commission, LCR Date: 2.20.2019



1940 Tax Photo

Charles H. Henkels, AIA
Architects

39 Bethune Street
Greenwich Village Historic District



39 Bethune as Pickwick Papers (undated)

Historic Photos



Bethune Street South Side, From and Including Washington Street, NYPL 709/C1

Charles H. Henkels, AIA
Architects

39 Bethune Street
Greenwich Village Historic District



41 Bethune Street Tax Photo 1940

Historic Photos



Photo 1: 39 Bethune Street Street Facade

Charles H. Henkels, AIA
Architects

39 Bethune Street
Greenwich Village Historic District



Photo 2: Bethune Street Street View Looking East



Photo 3: Bethune Street Street View Looking West

Existing Conditions Photos



Photo 4: From 35 Bethune Street Looking Southwest towards Washington Street



Photo 5: From 35 Bethune Street Looking West Towards Washington Street



Photo 6: 39 Bethune Street Existing Greenhouse at Terrace Looking North



Photo 7: 39 Bethune Street Existing Greenhouse



Photo 8: 39 Bethune Street Existing Terrace Looking Southwest



Photo 9: 39 Bethune Street Existing Terrace Looking East



Photo 9: West side of Washington Street looking east over Lichtenstein Foundation one story building. No visibility from Washington Street. West red brick wall of 35 Bethune Street is visible.

Charles H. Henkels, AIA
Architects

39 Bethune Street
Greenwich Village Historic District

Existing Conditions Photos

7.1

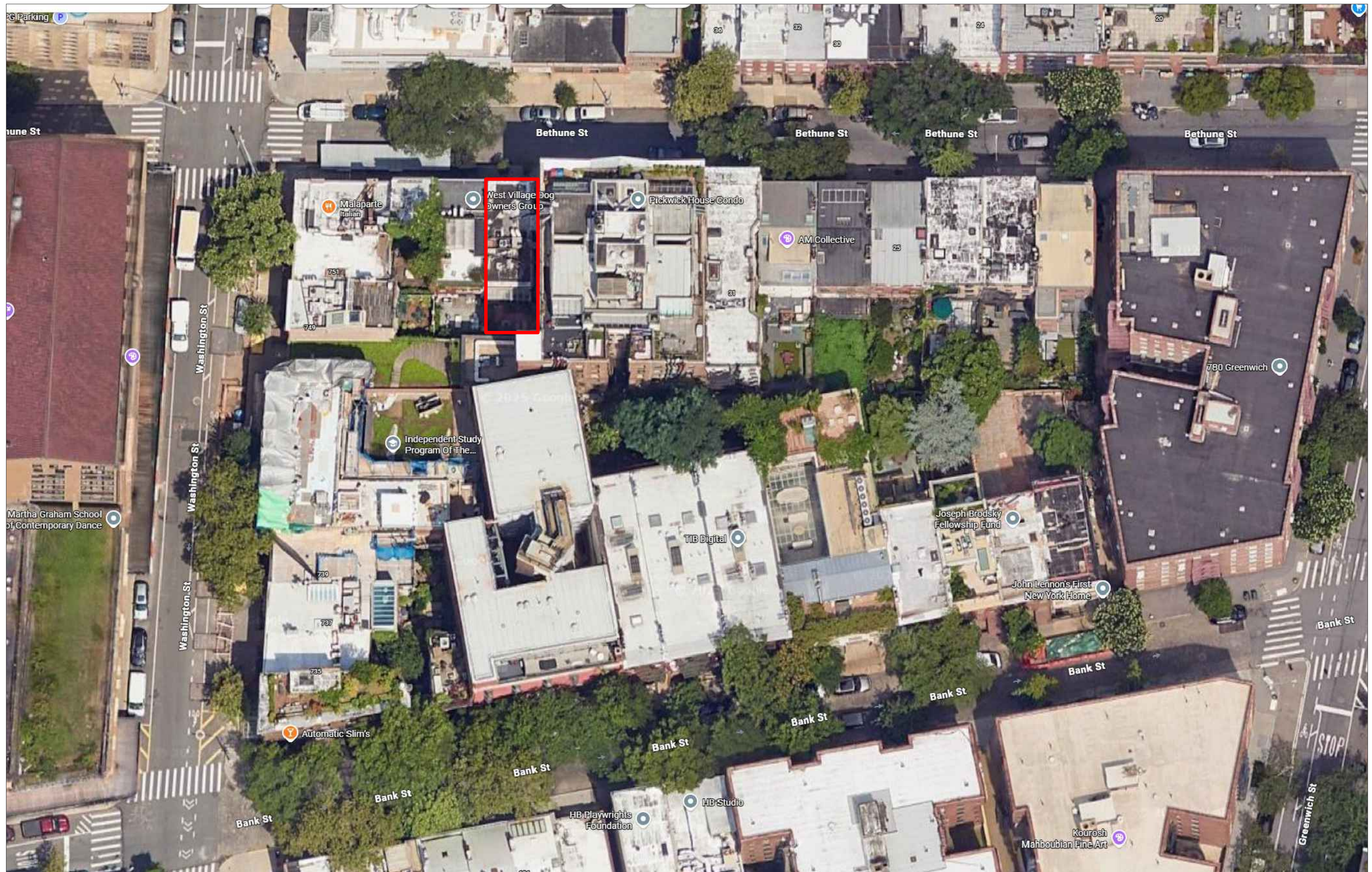

Source: Google Maps

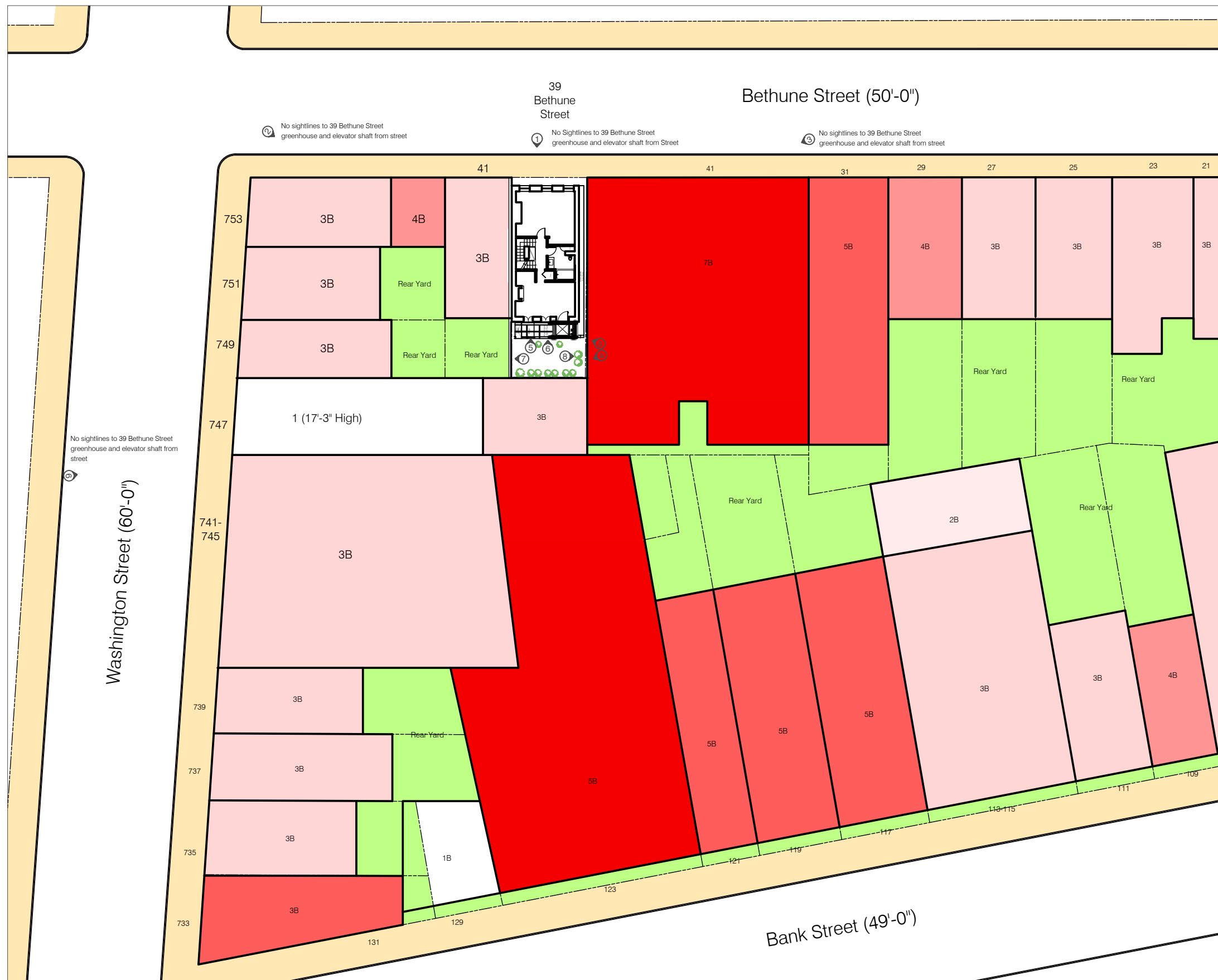

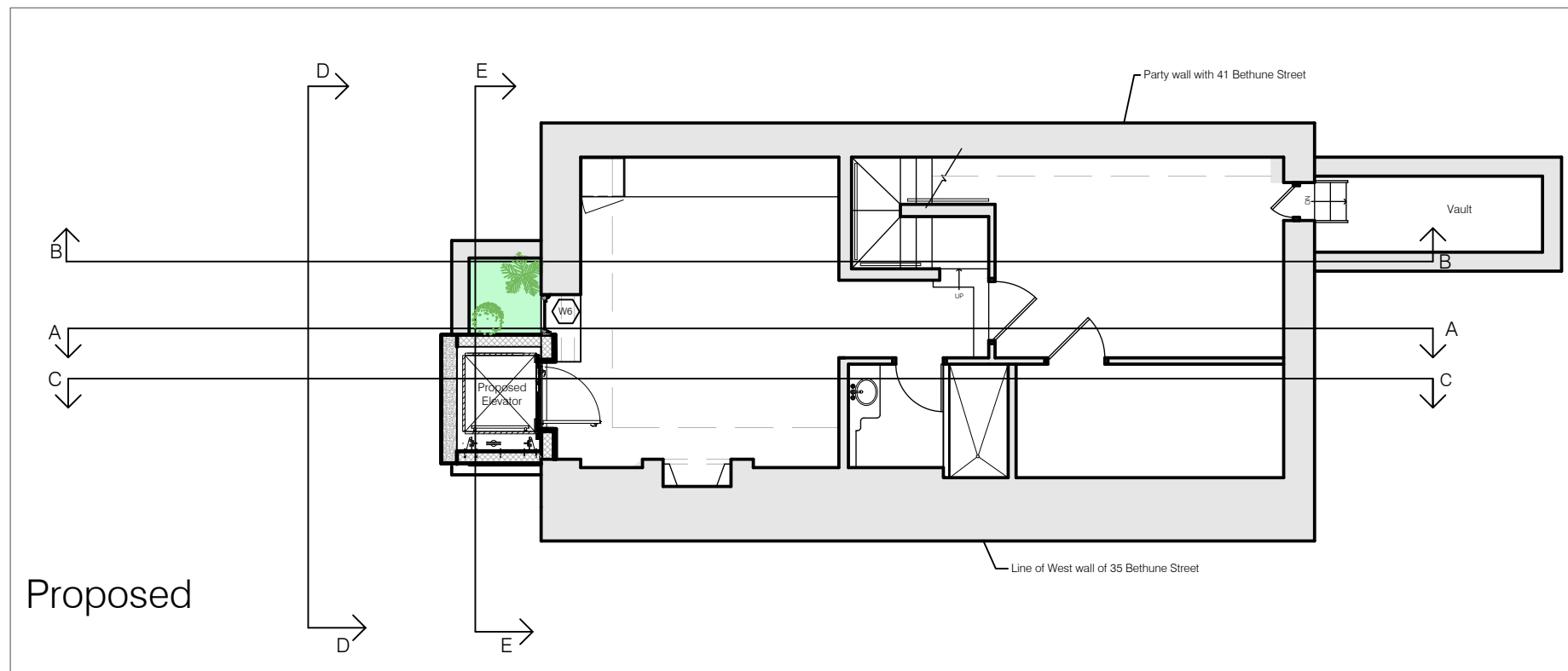
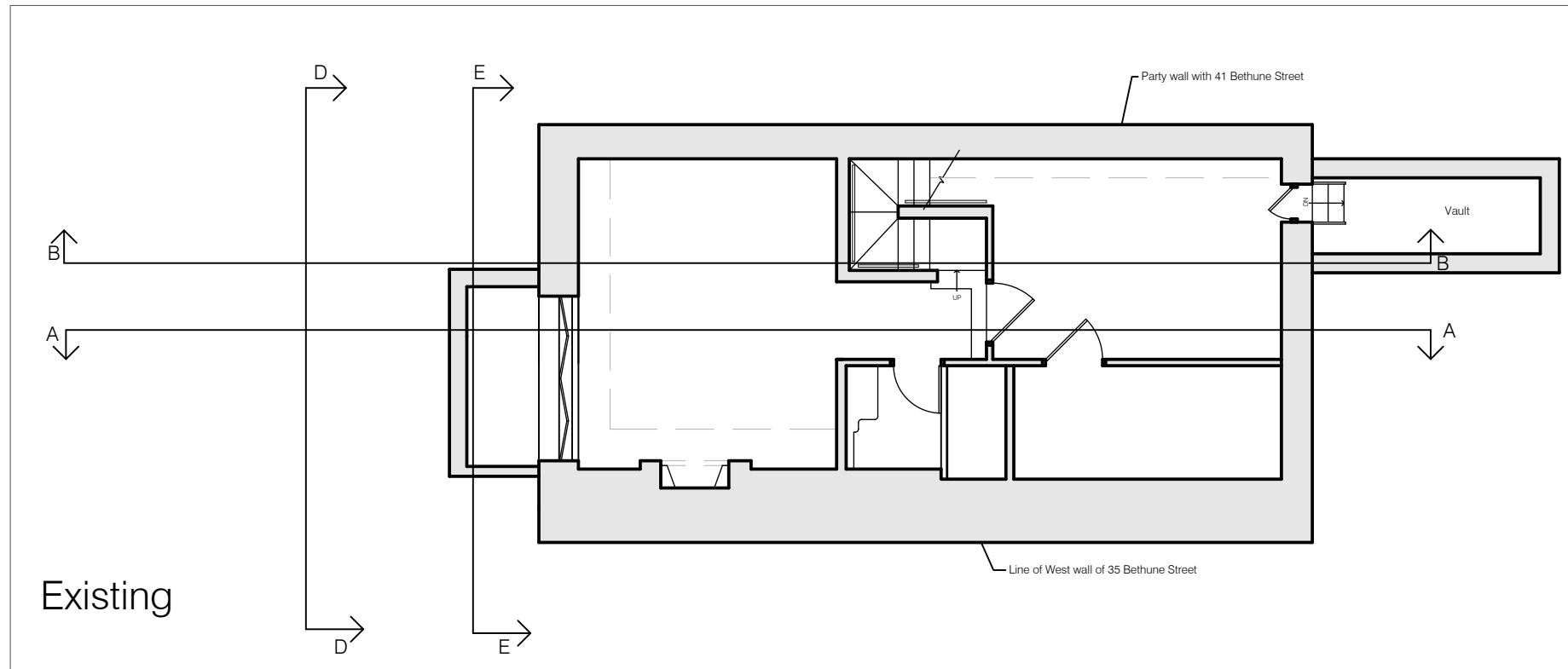

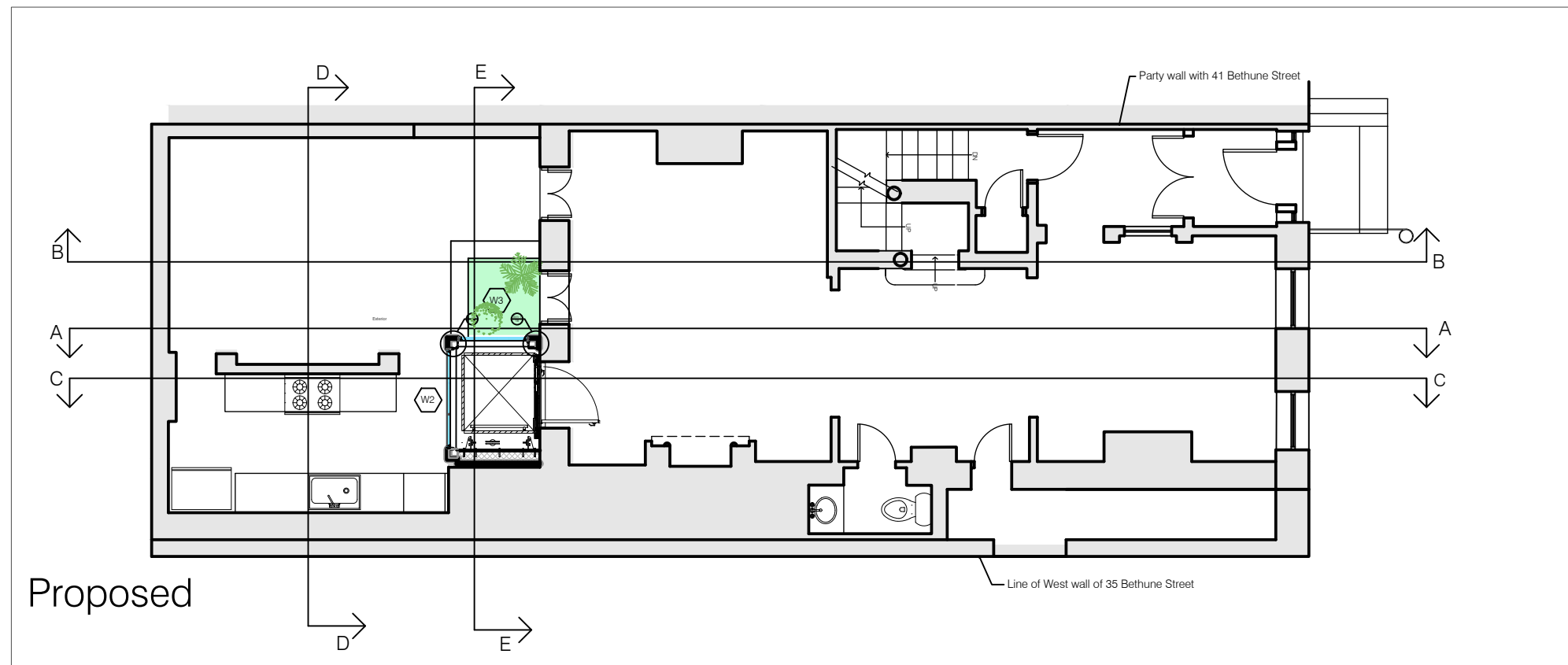
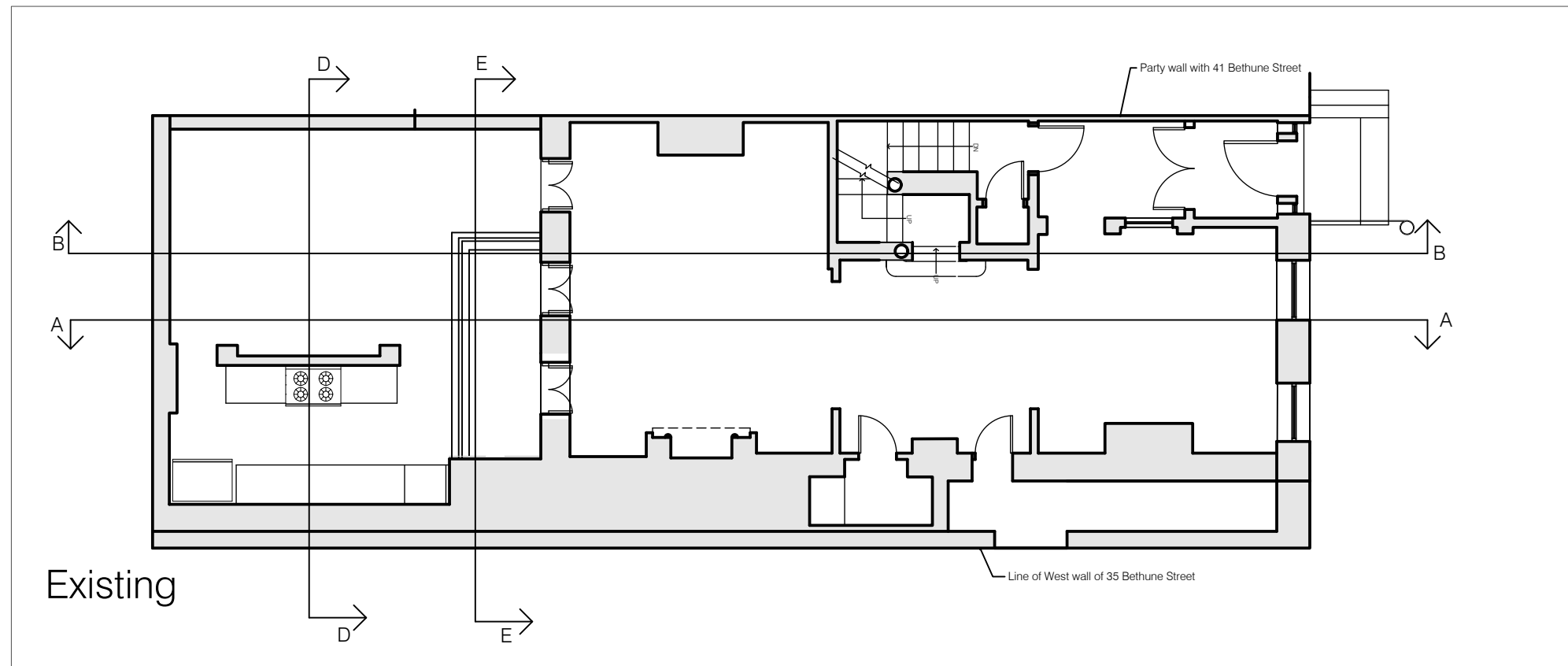

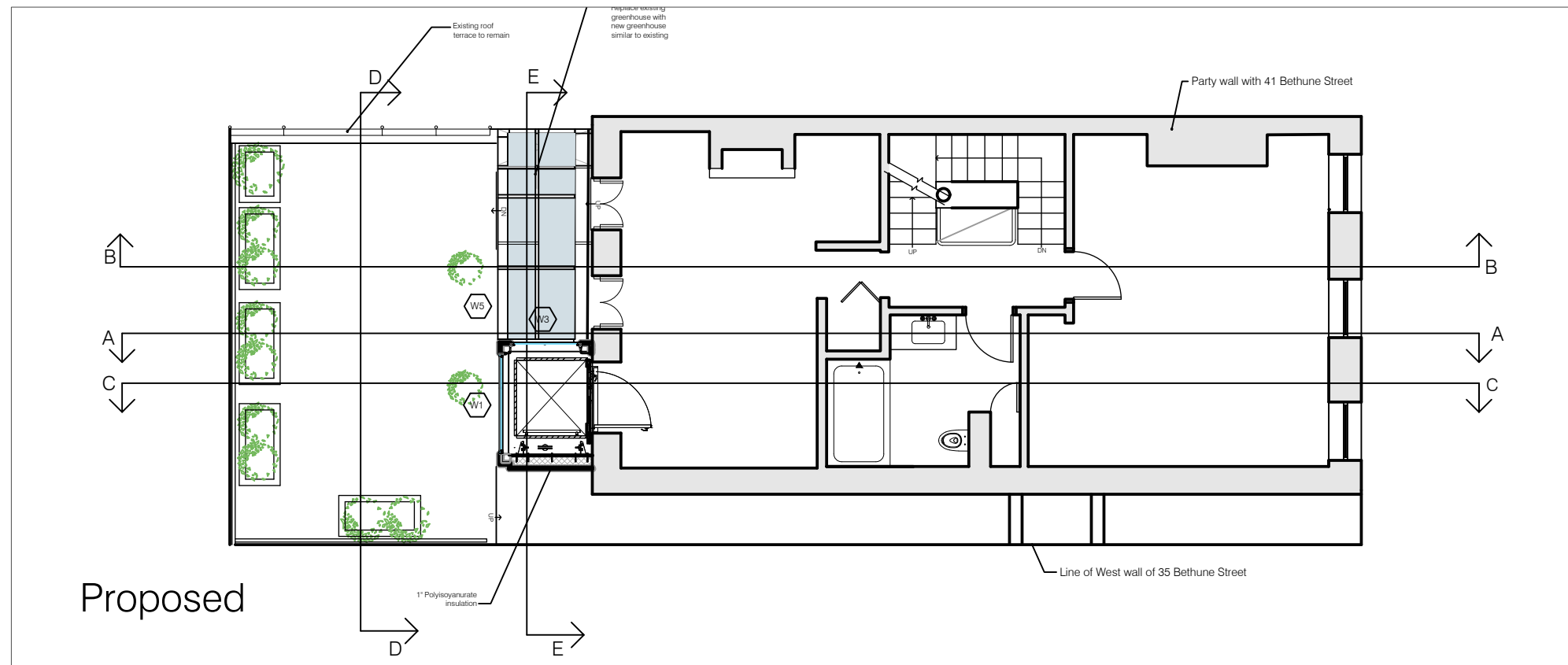
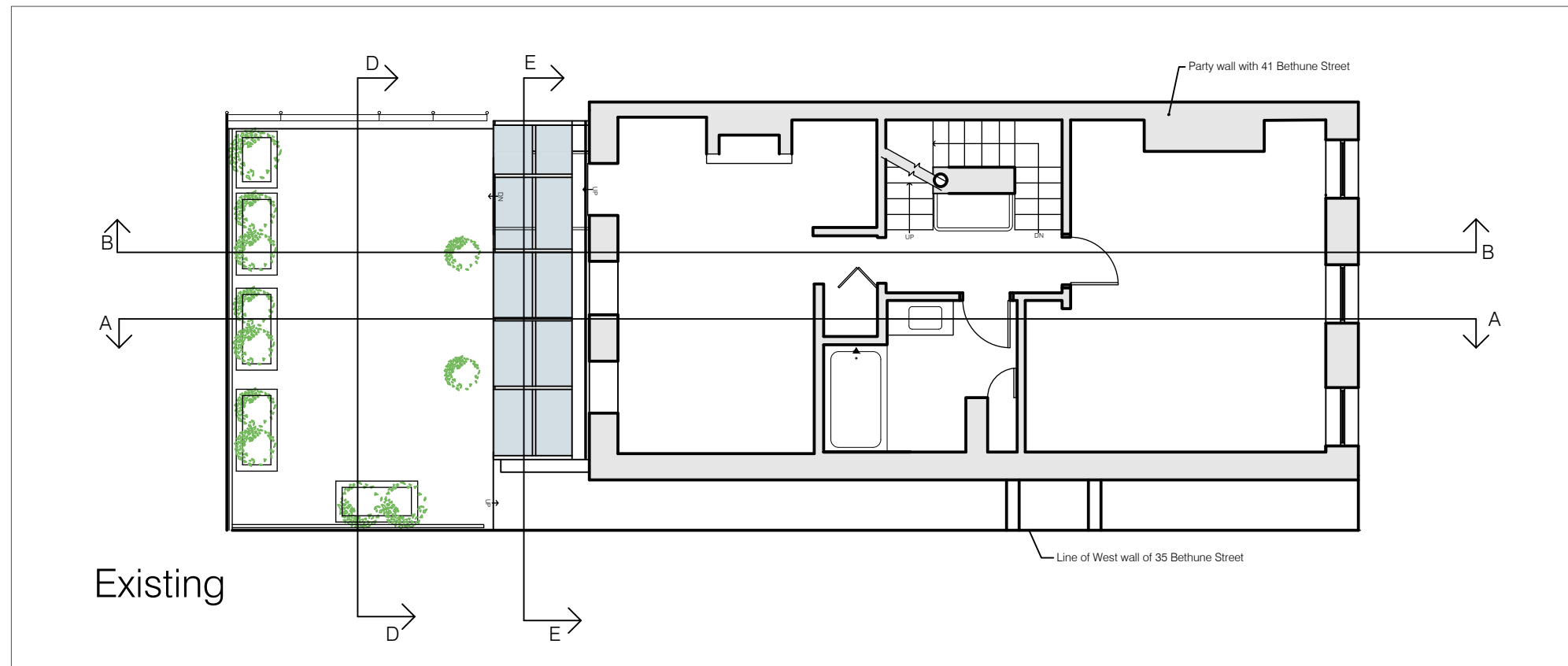

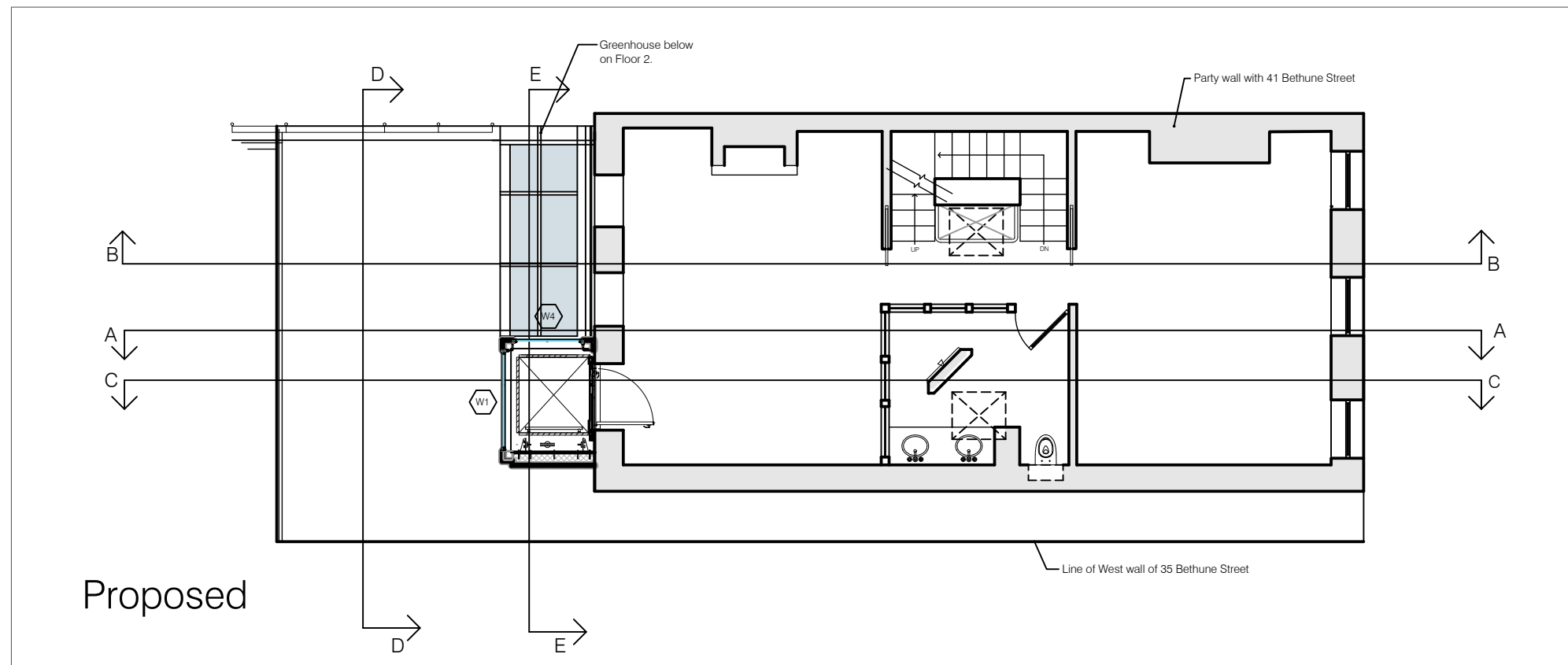
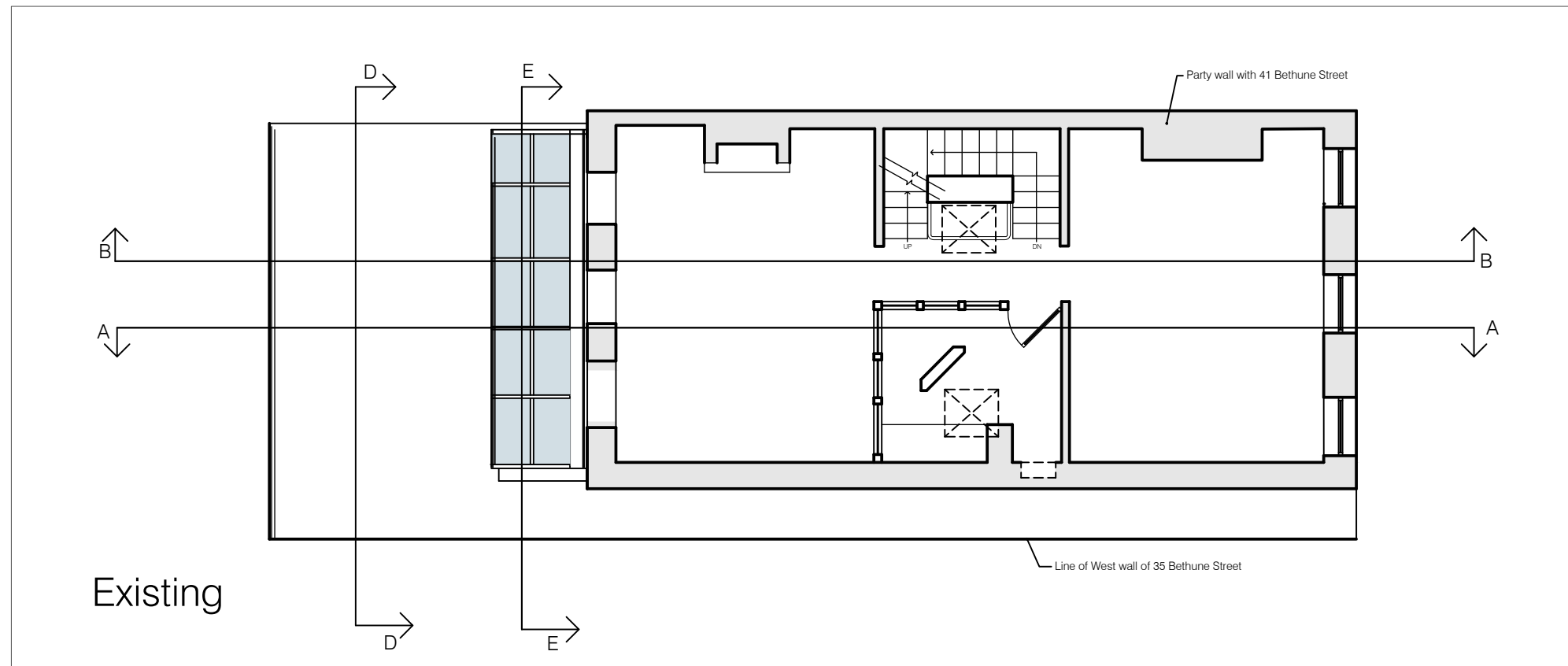

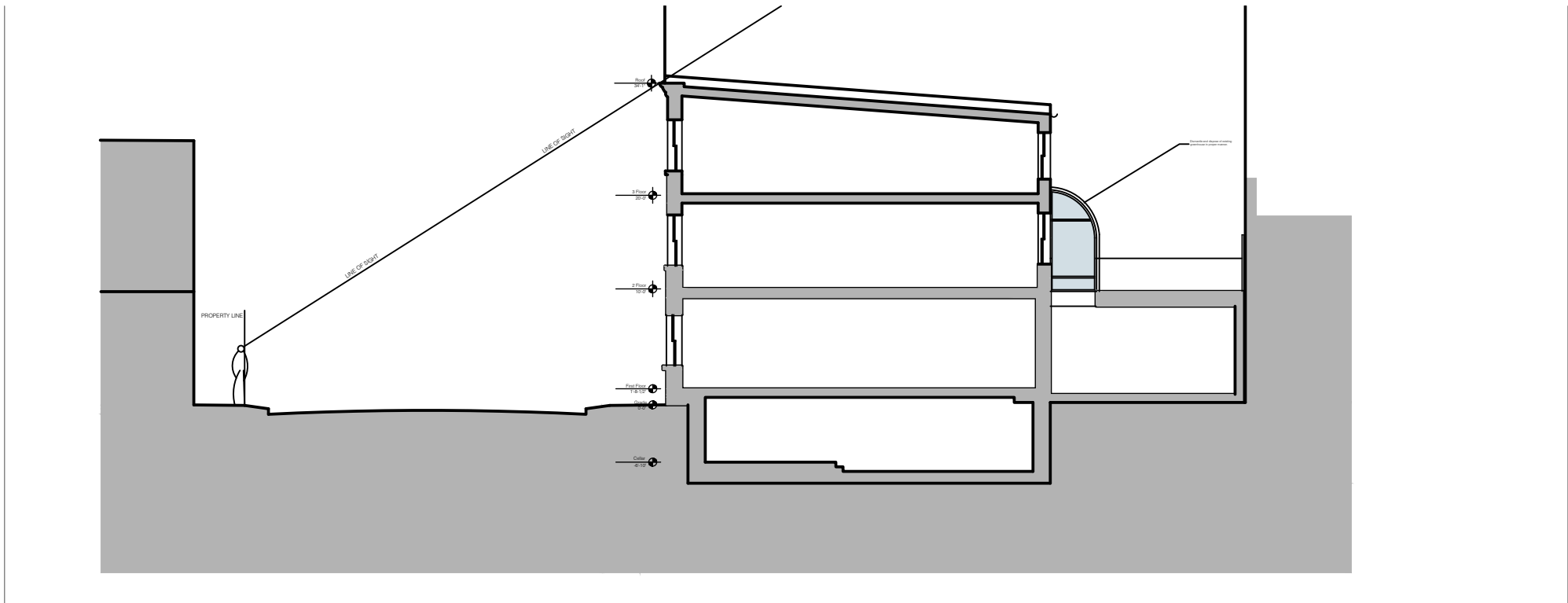

Existing

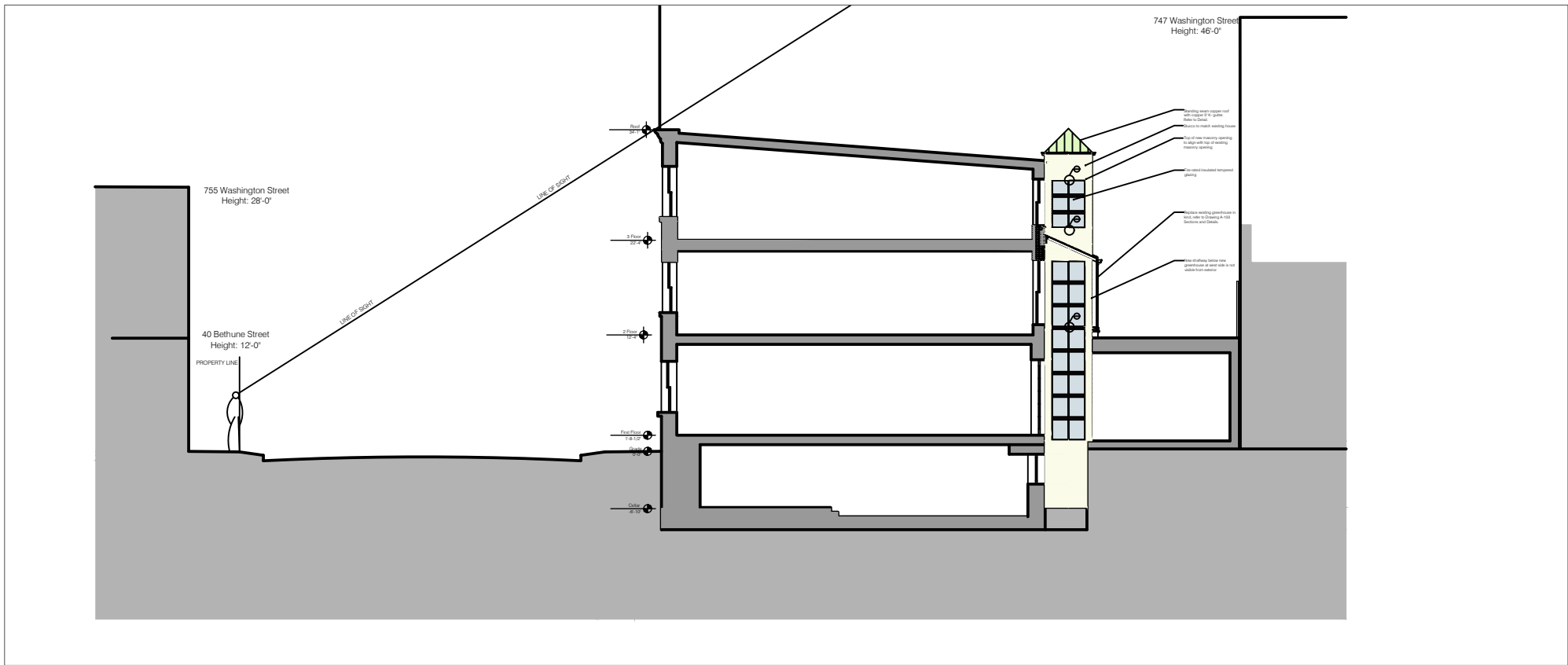

Proposed

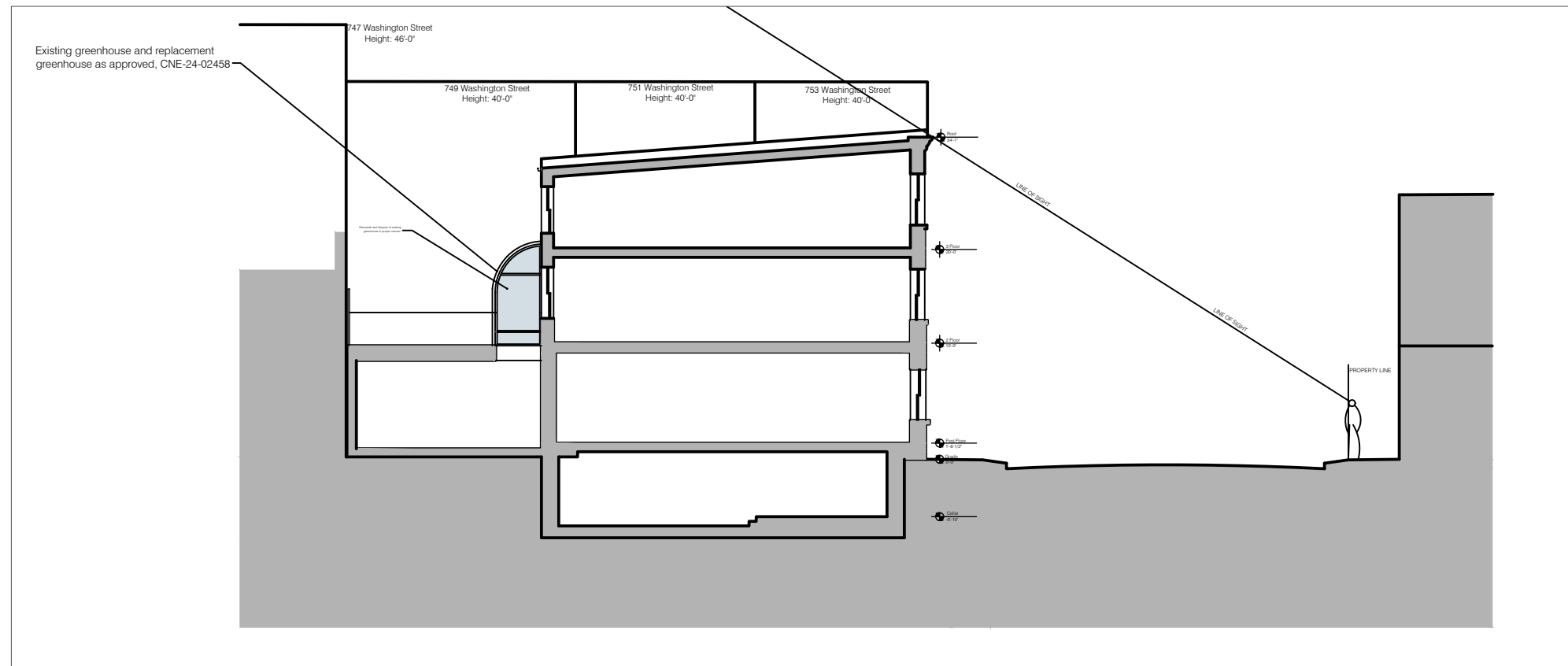

Existing

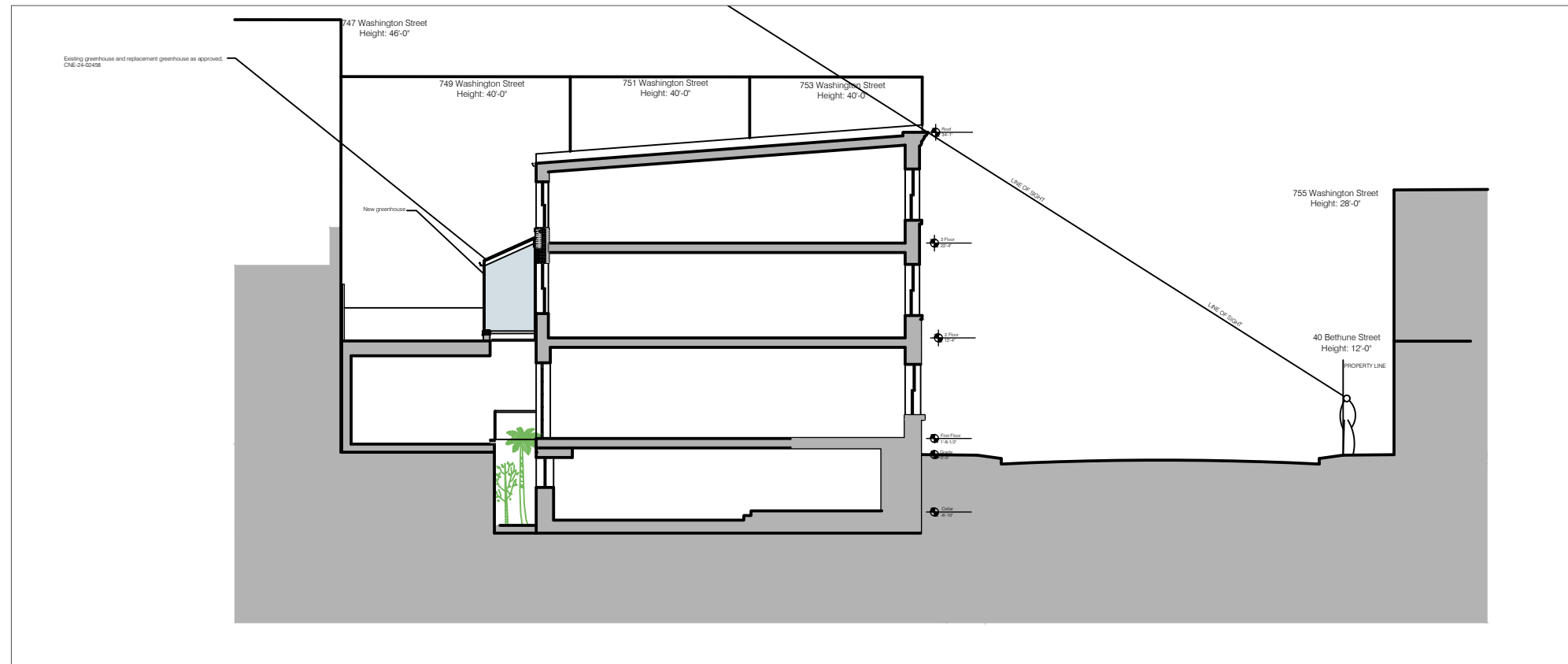

Proposed

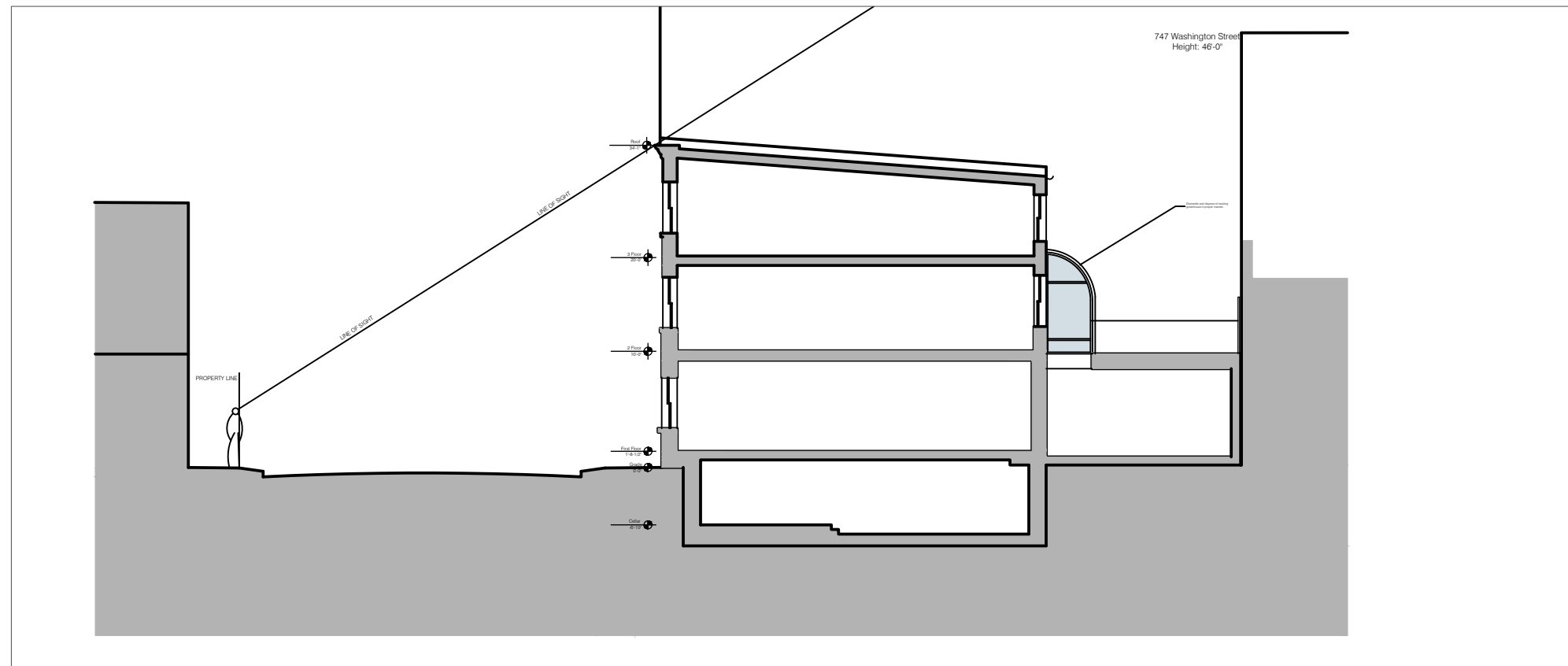

Existing

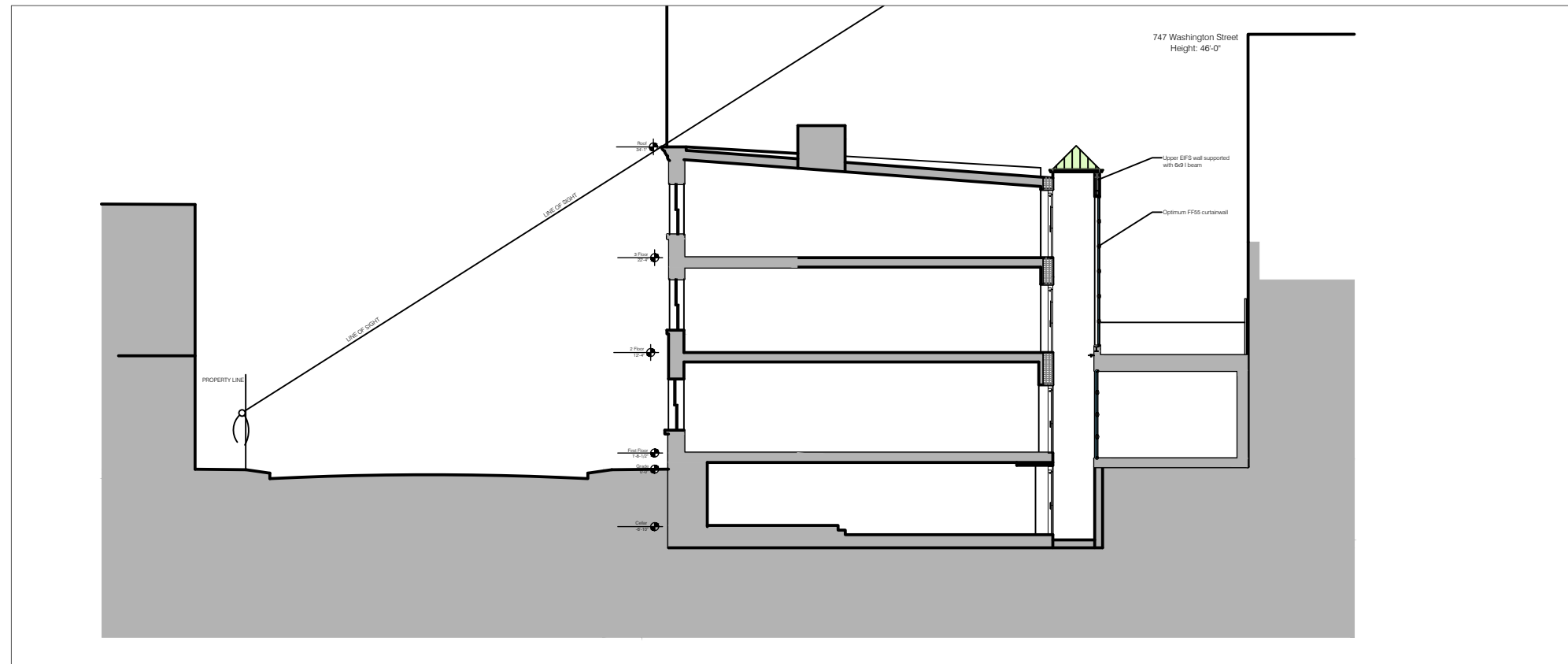

Proposed

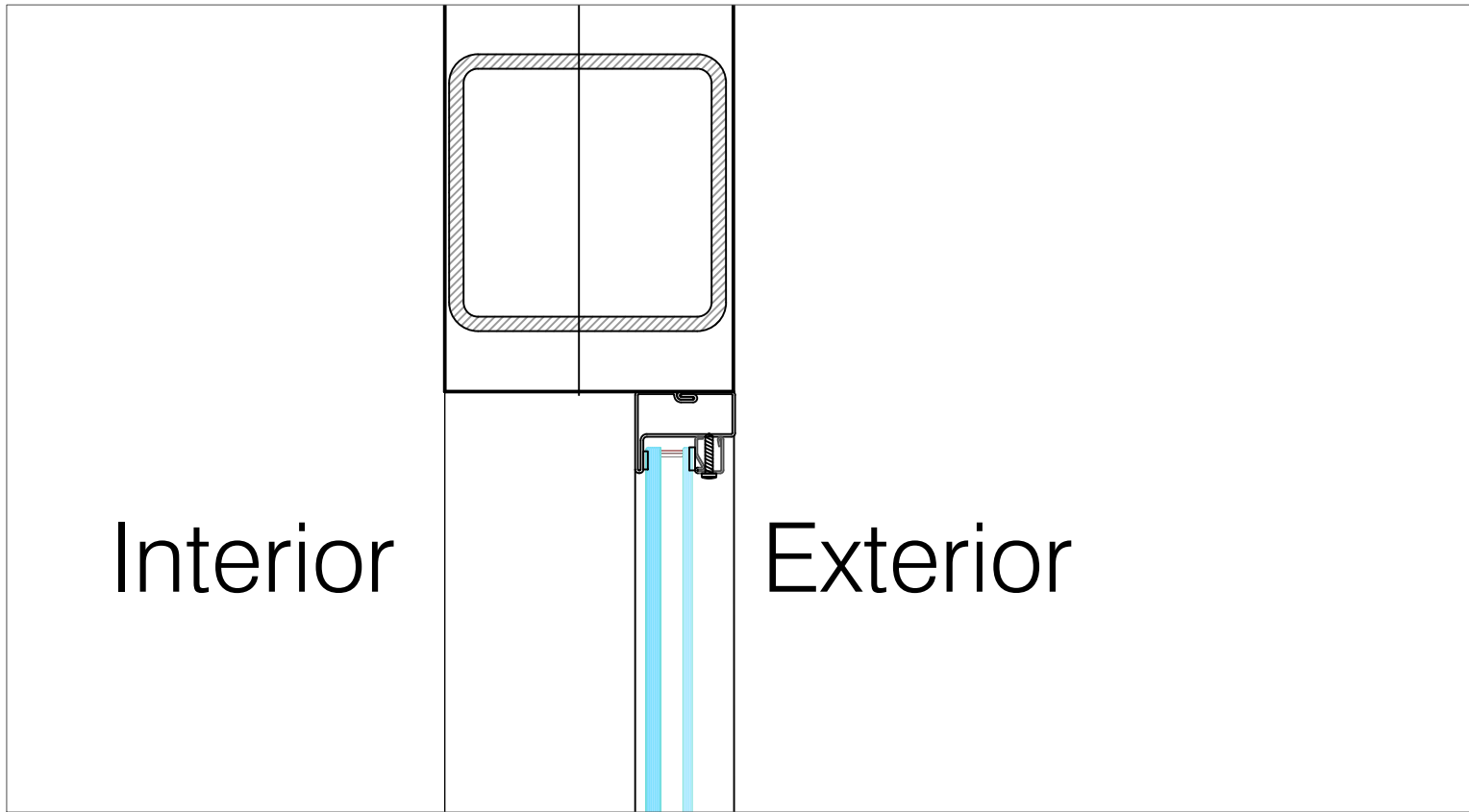

1
A-17 Glazing Section at Head

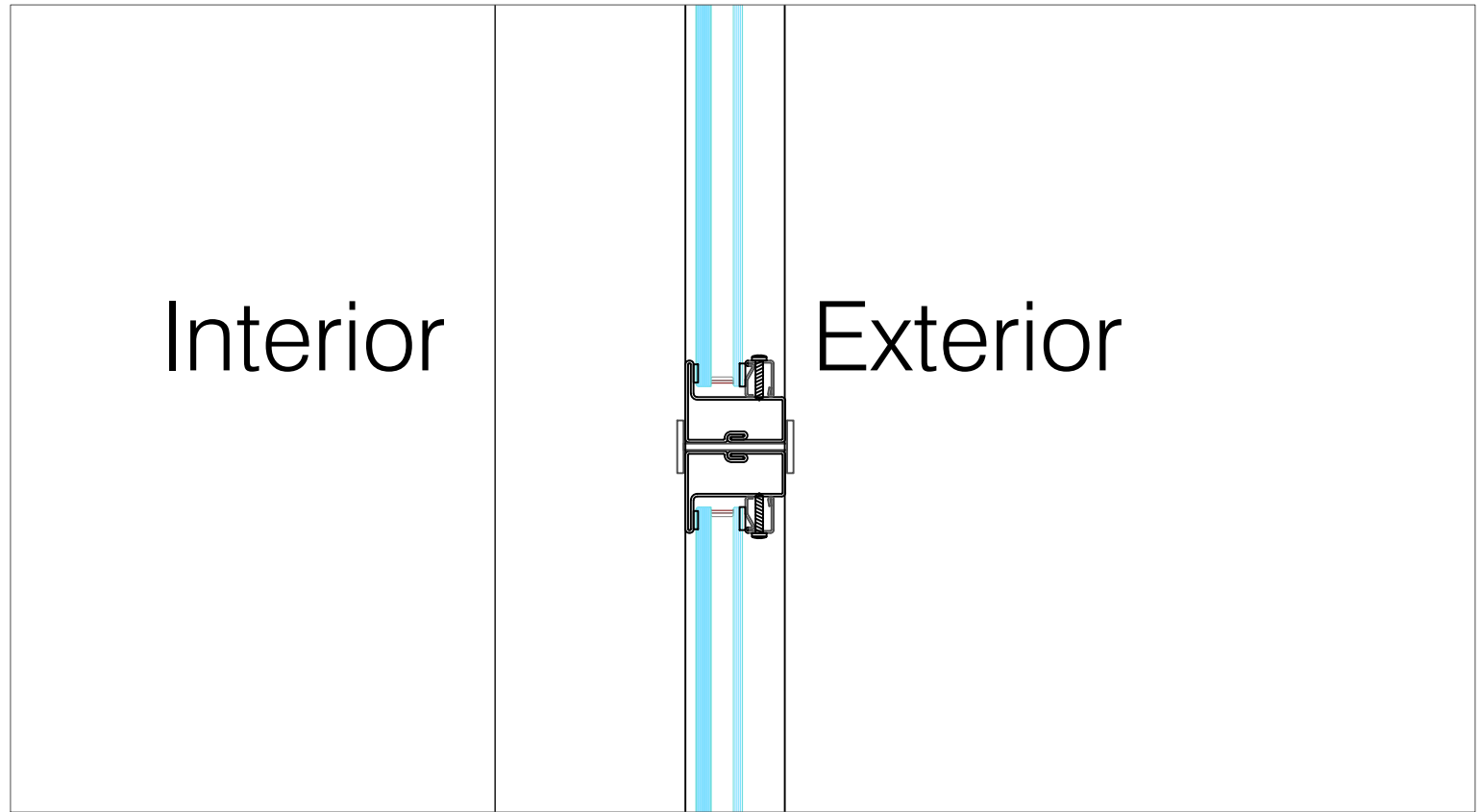

3
A-17 Glazing Section at Mullion

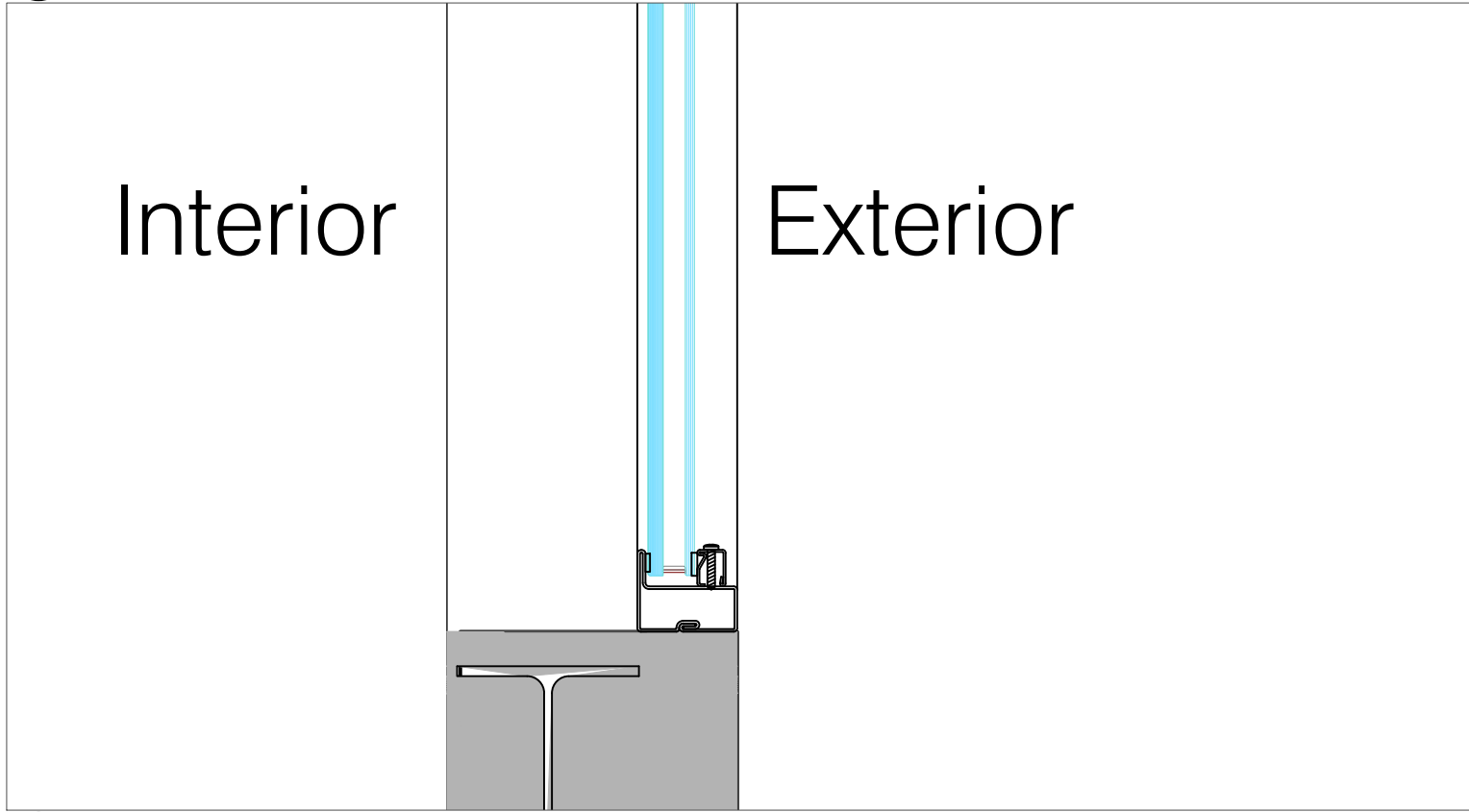

2
A-17 Glazing Section at Sill

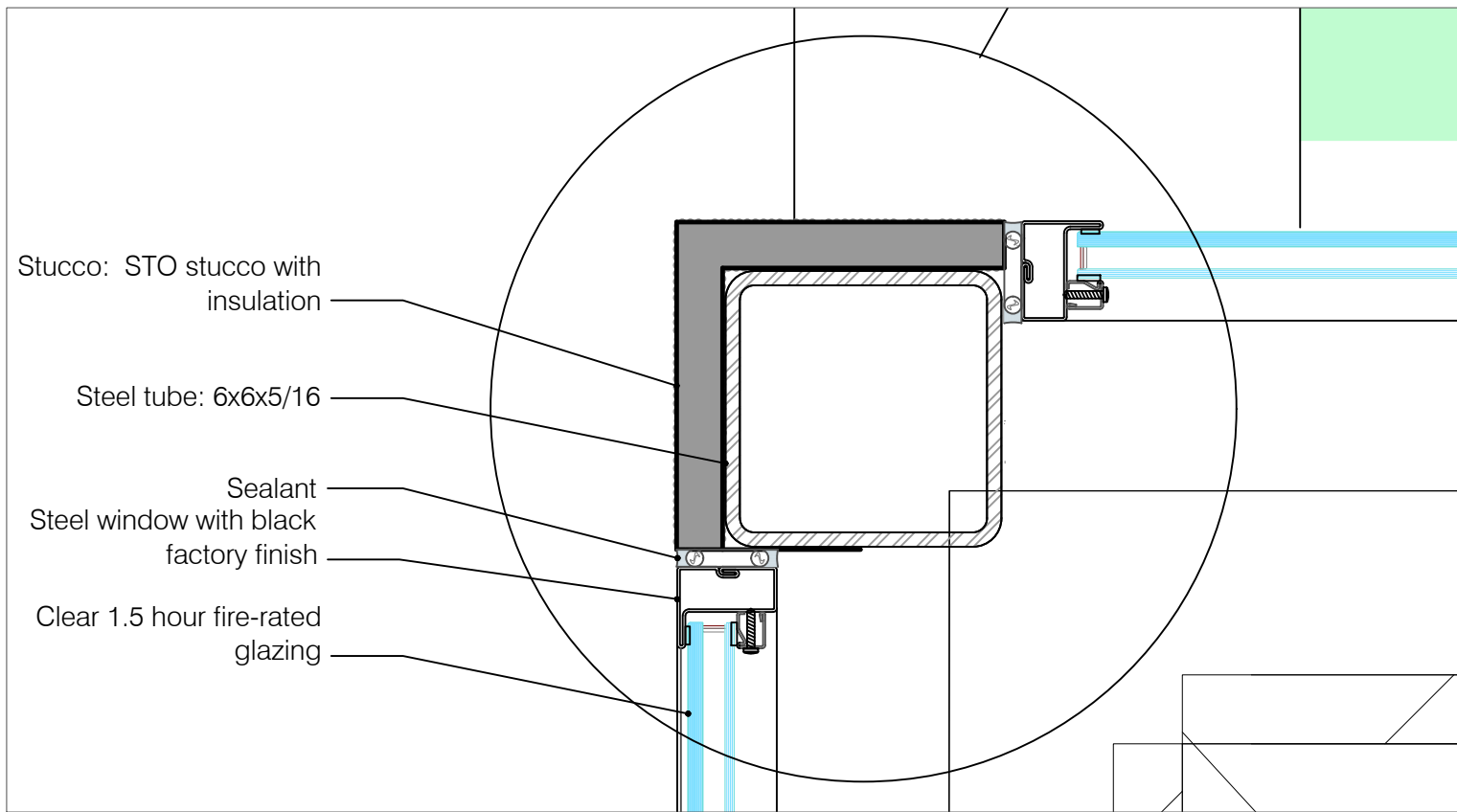

1
A-18 Glazing Section at Steel Tube

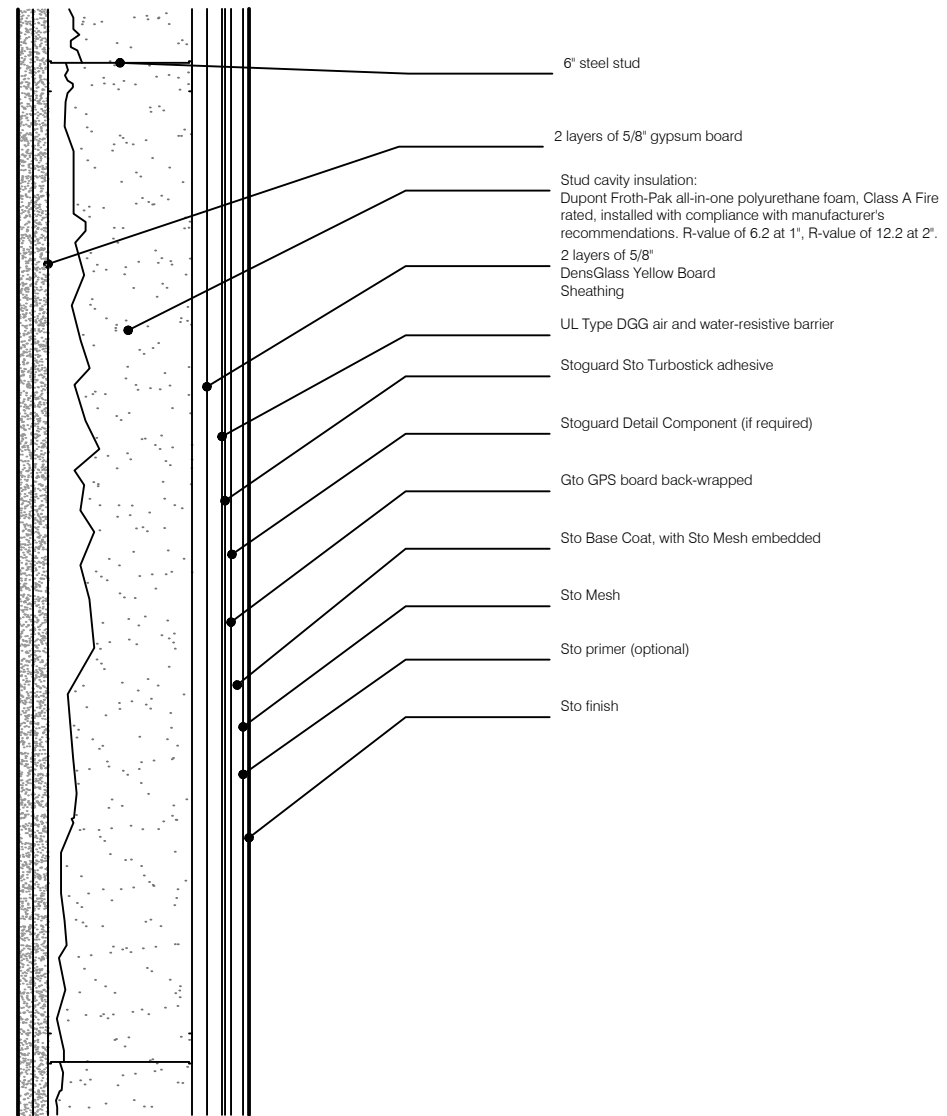

UPPER WALL

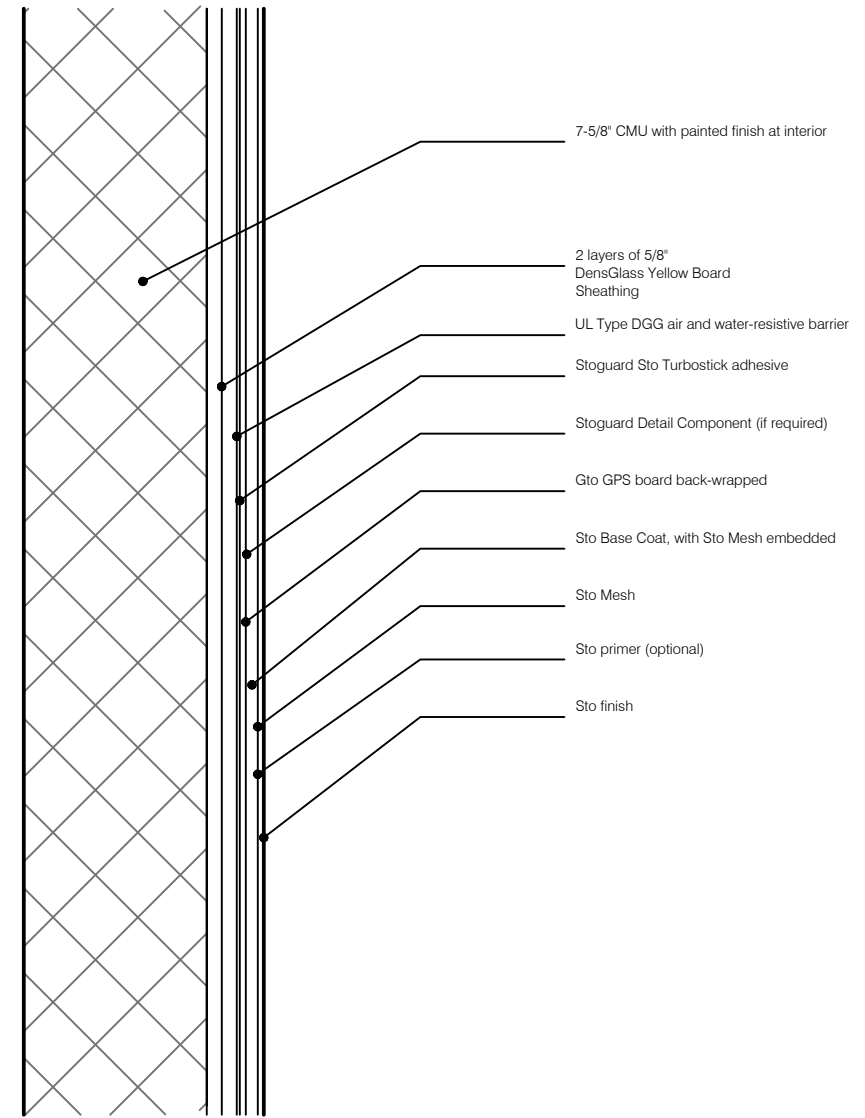

LOWER WALL

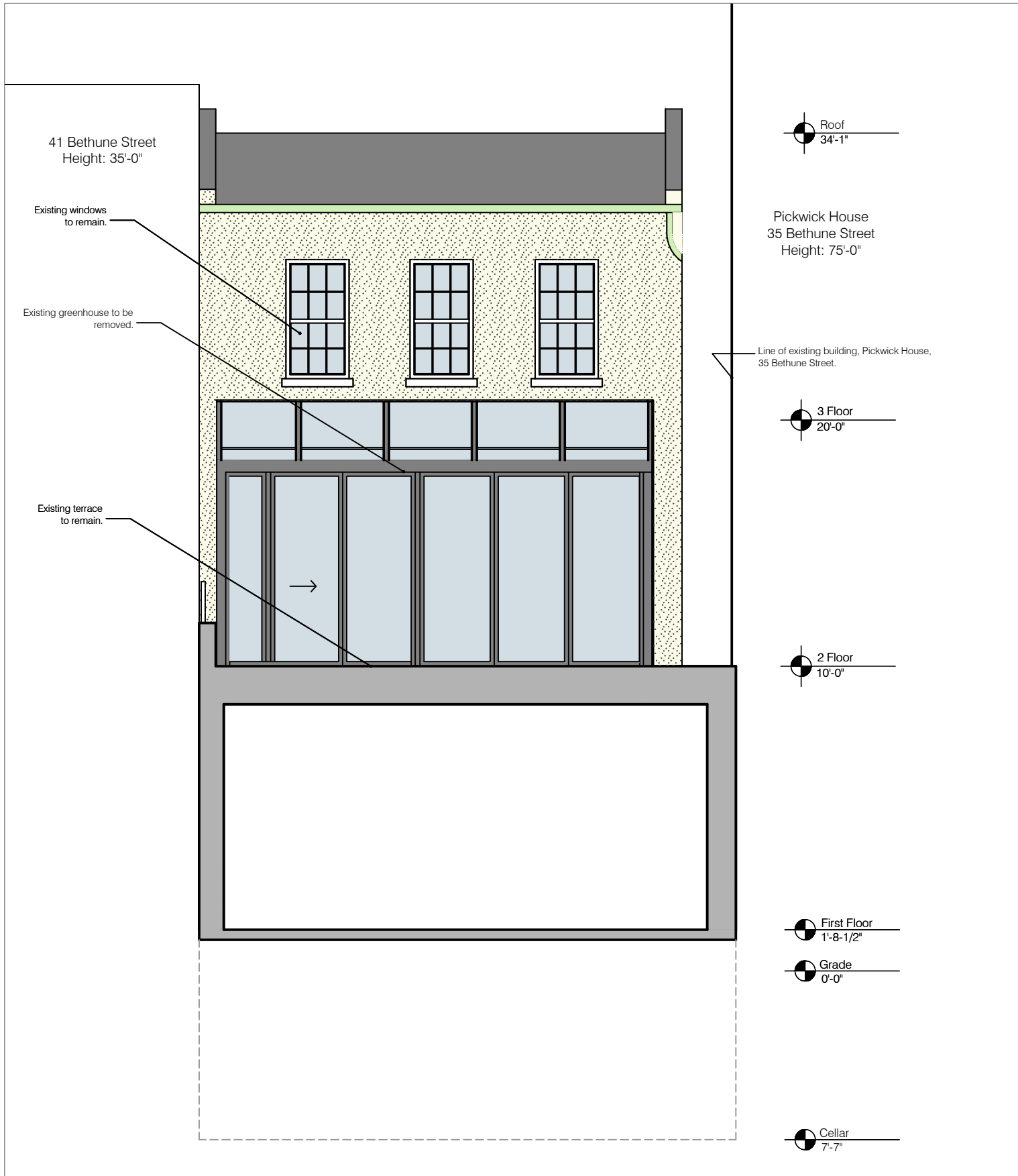

Existing



Proposed

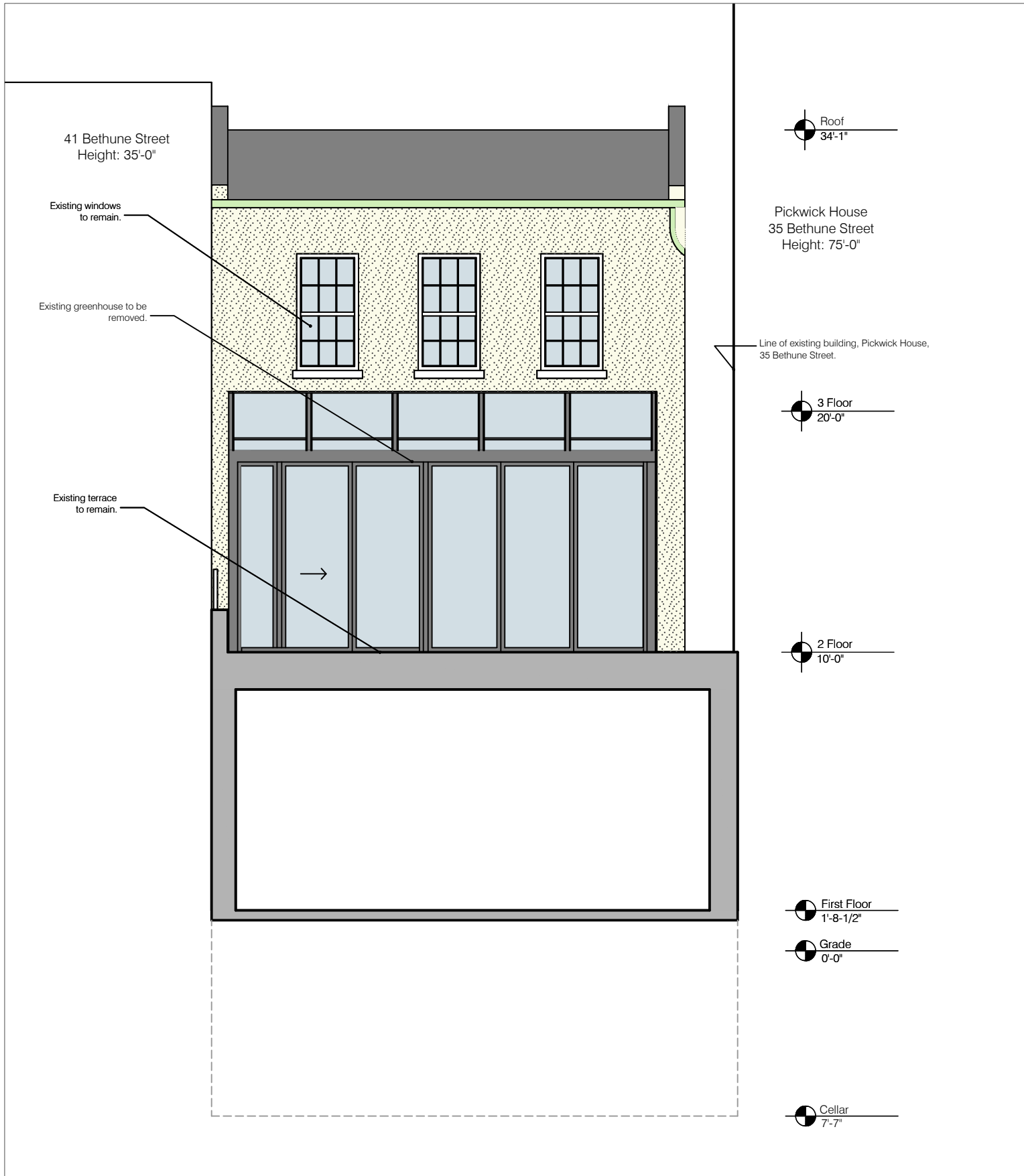

Existing

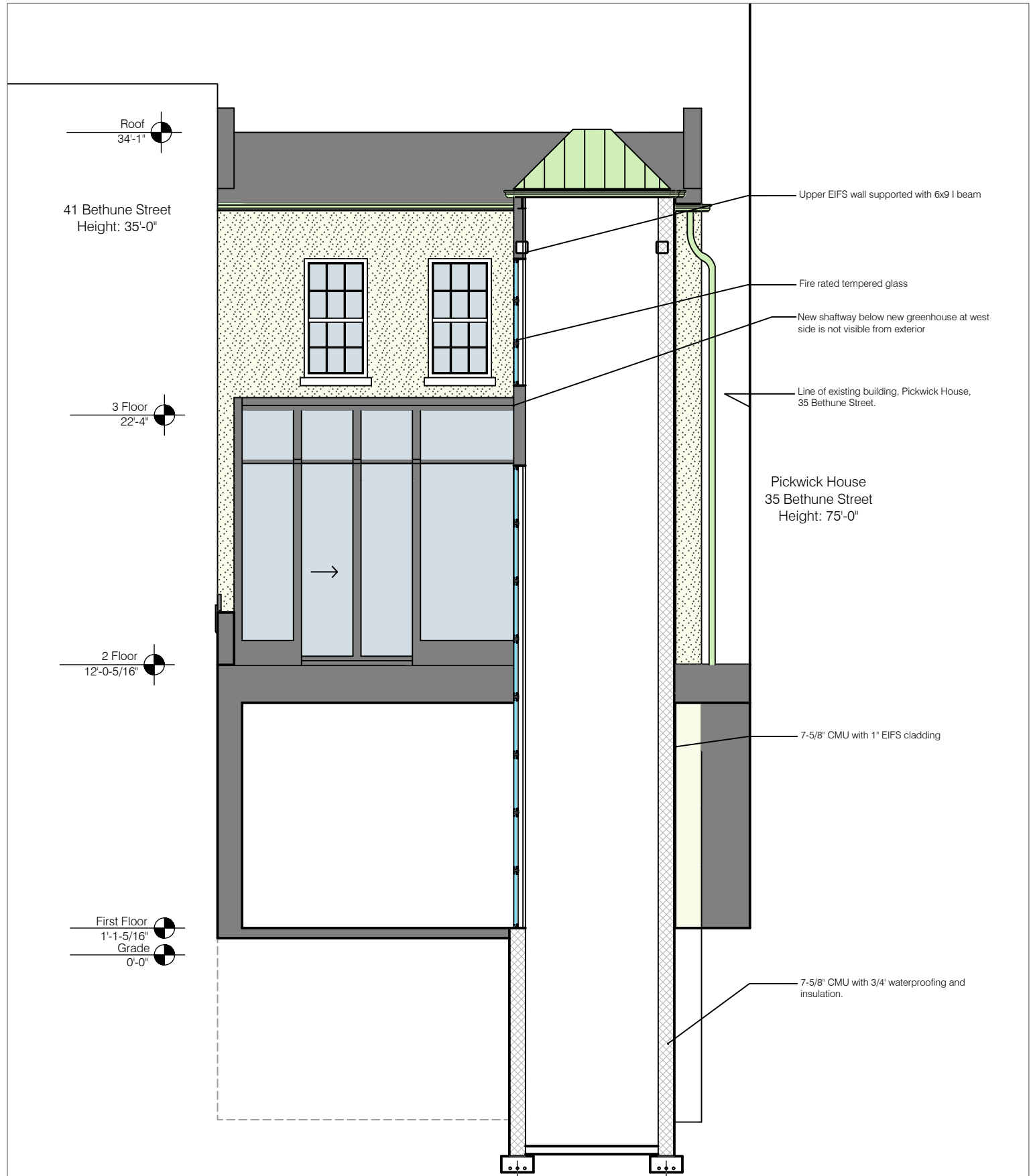

Proposed

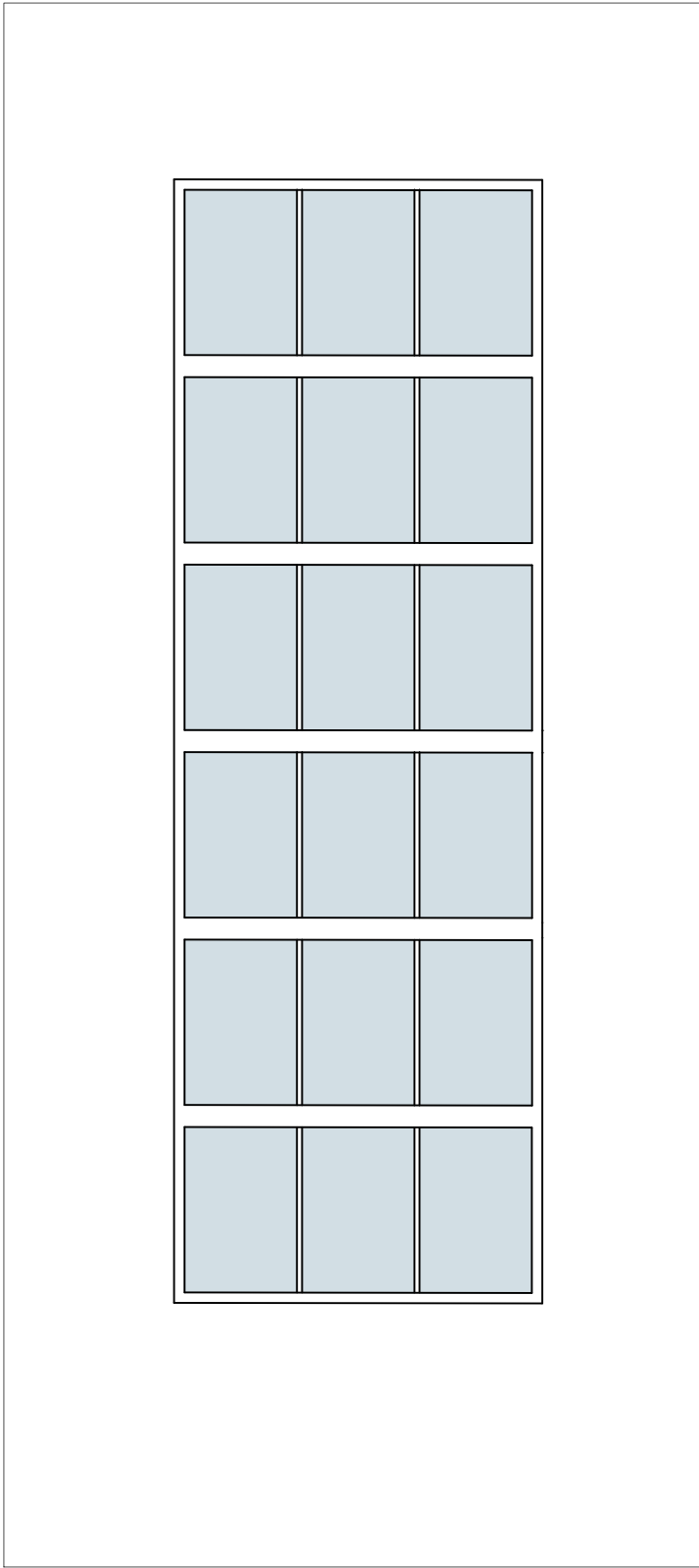

Elevation

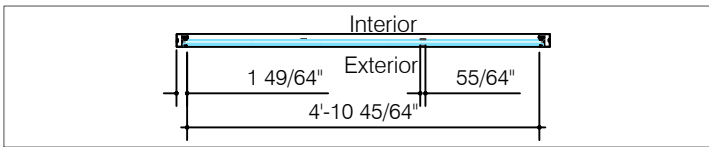

Plan

Charles H. Henkels, AIA
 Architects

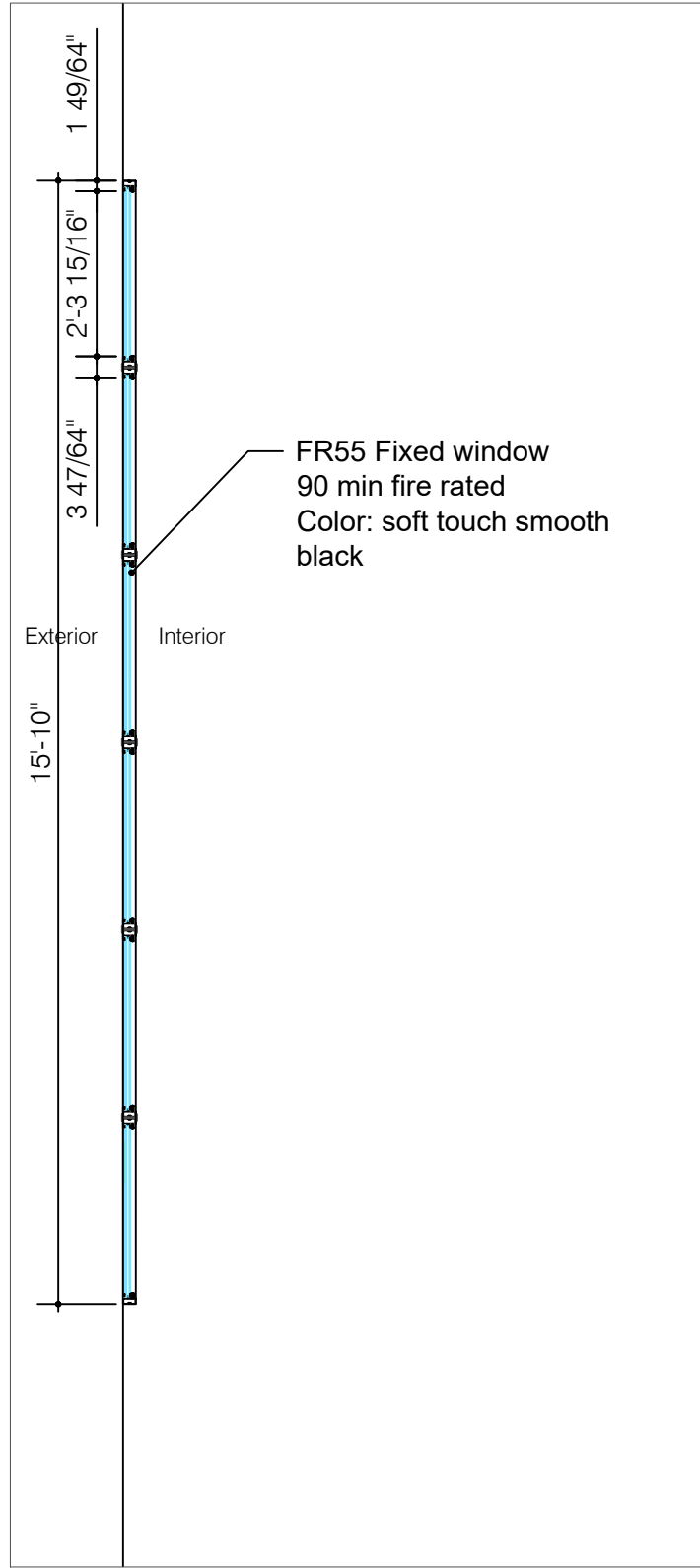

Section

Upper South Window 1

39 Bethune Street
 Greenwich Village Historic District

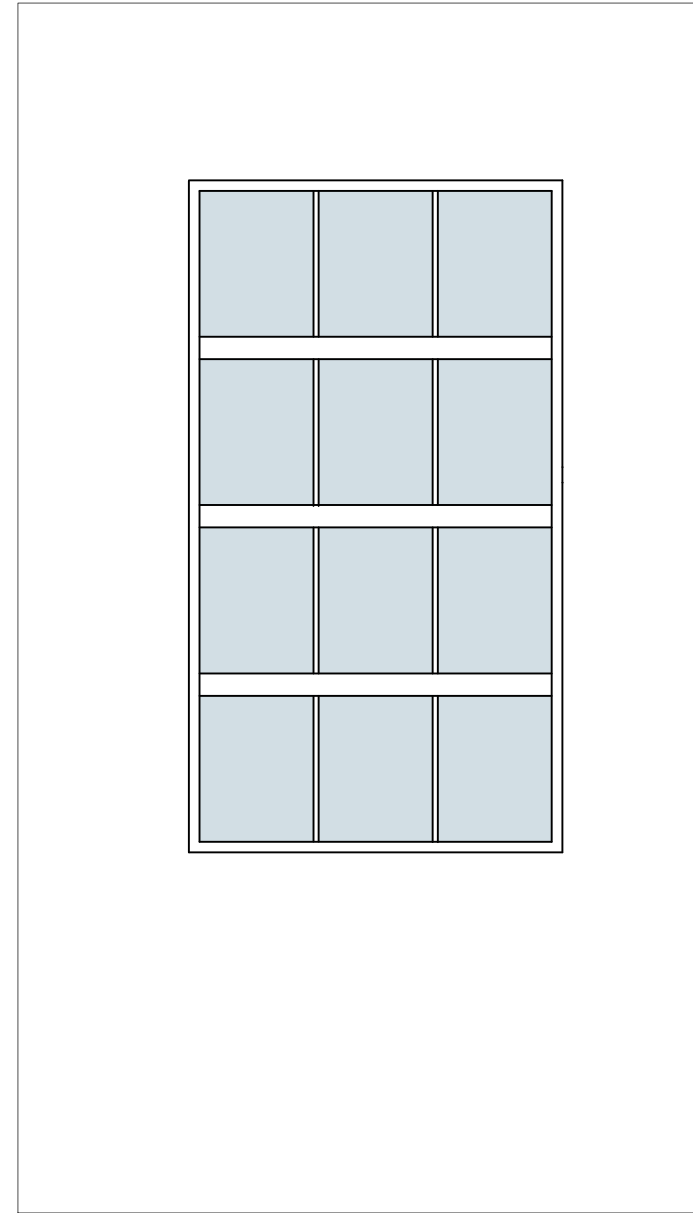

Plan

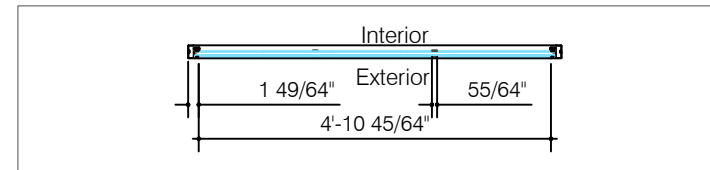

Glazing Details Windows 1 & 2

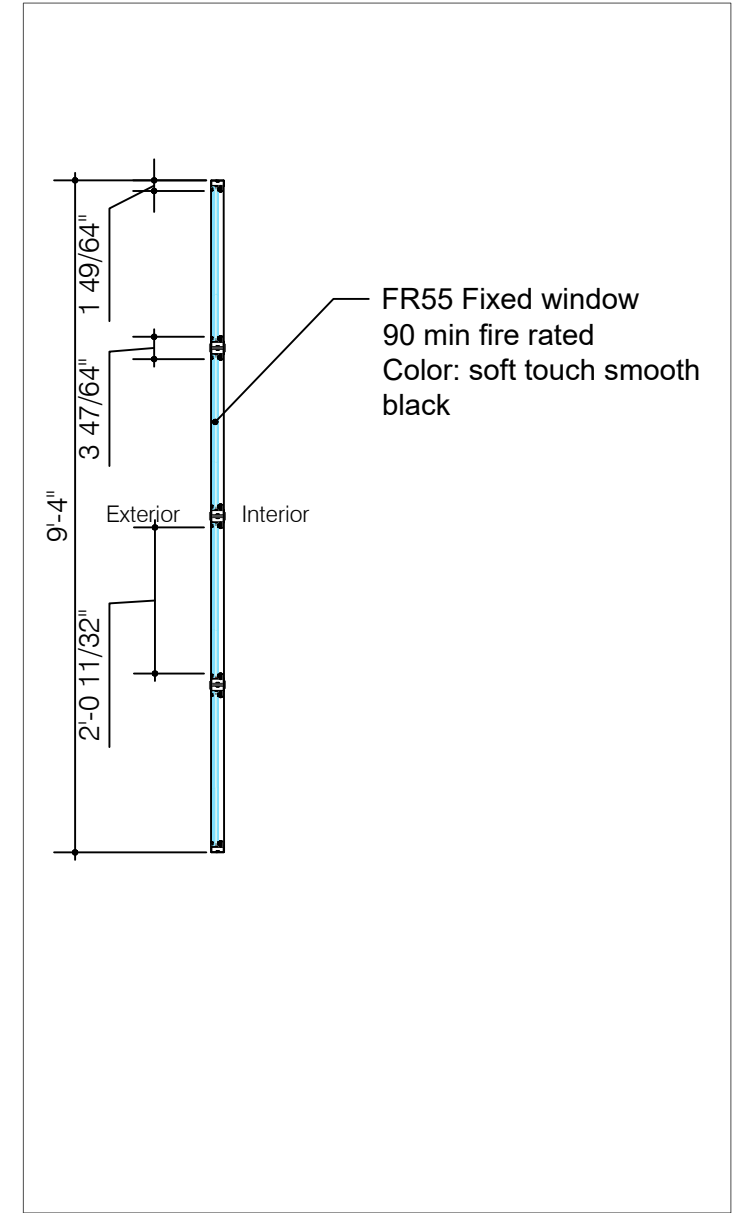

Lower South Window 2

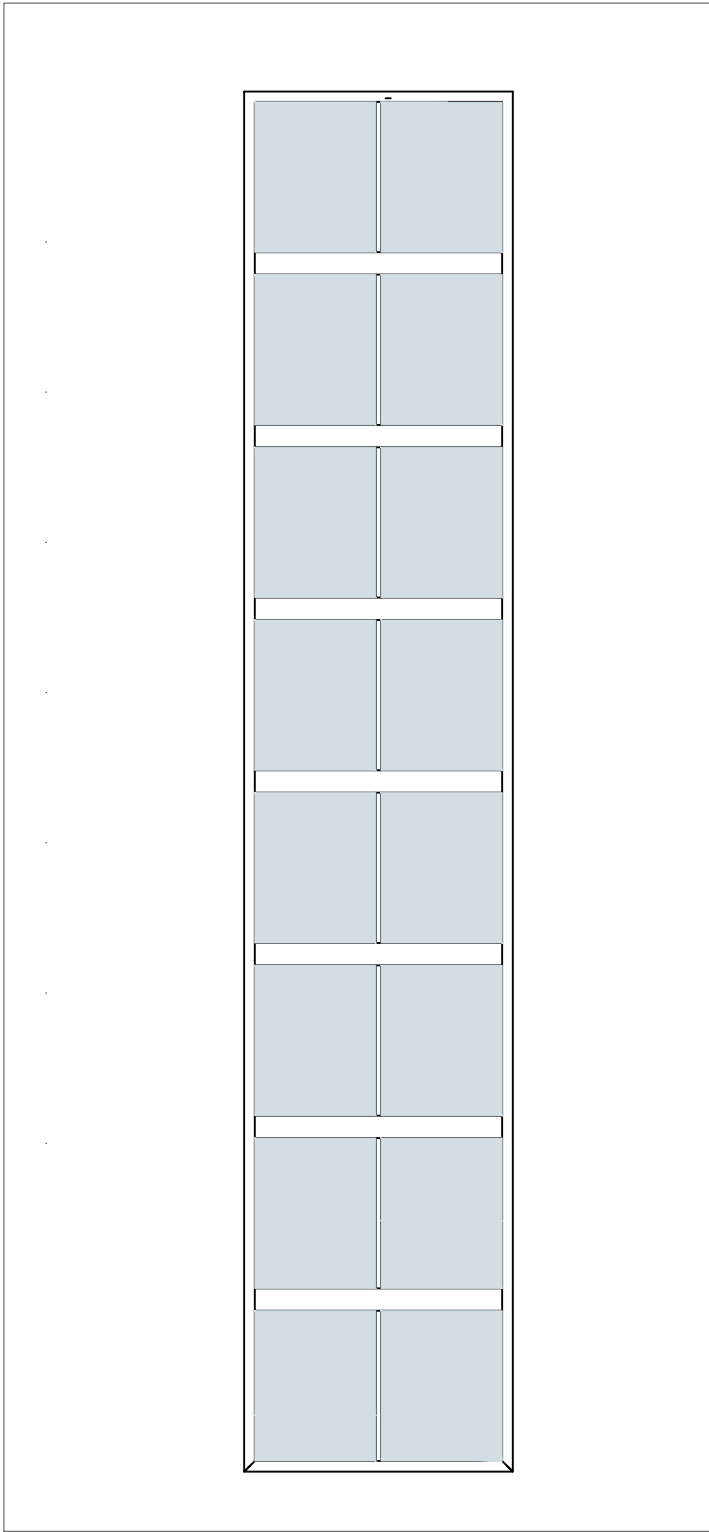

Elevation

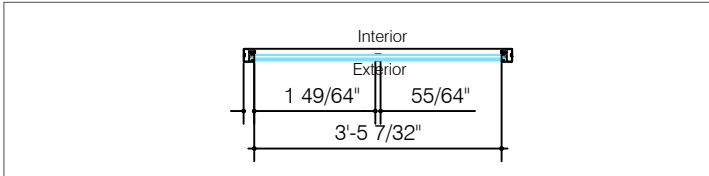

Plan

Charles H. Henkels, AIA
Architects

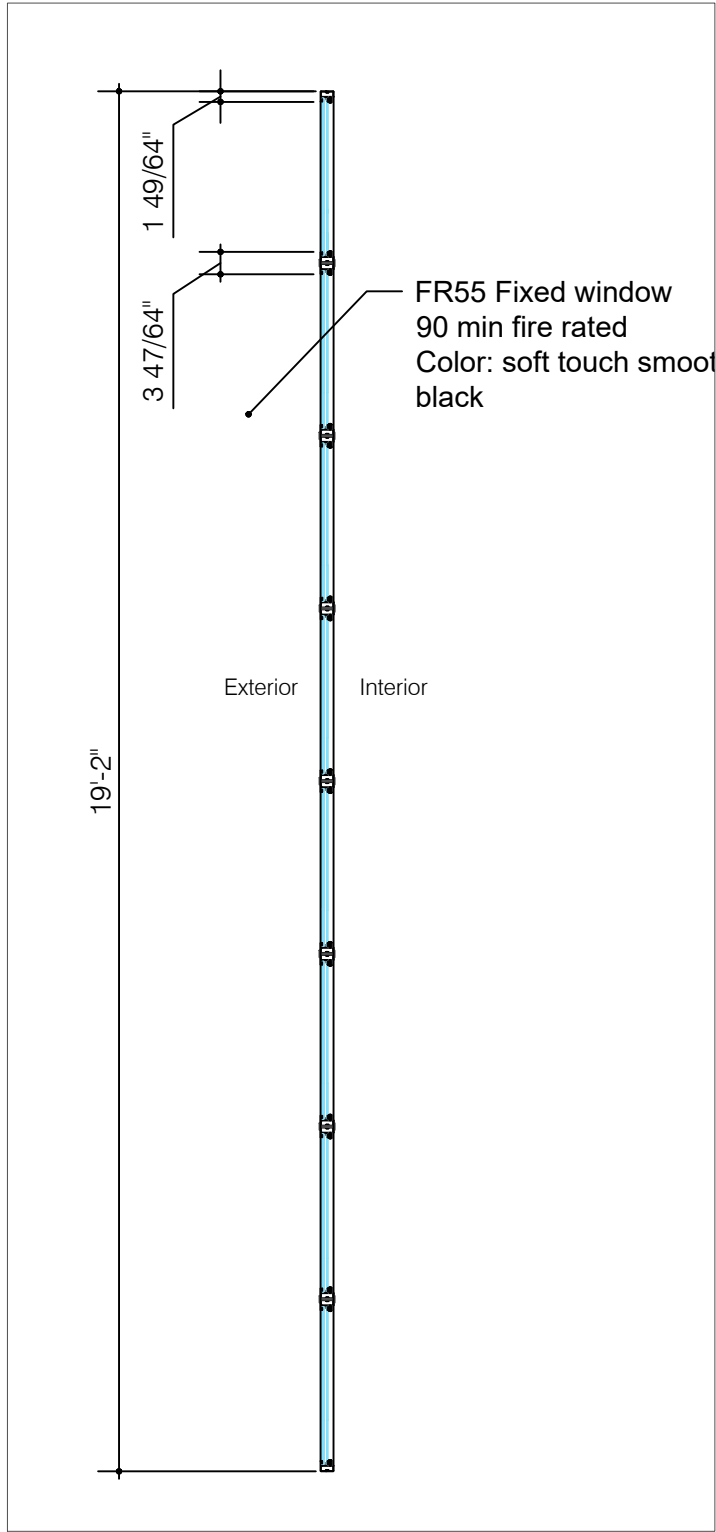

Section

Upper West Window 3

39 Bethune Street
Greenwich Village Historic District

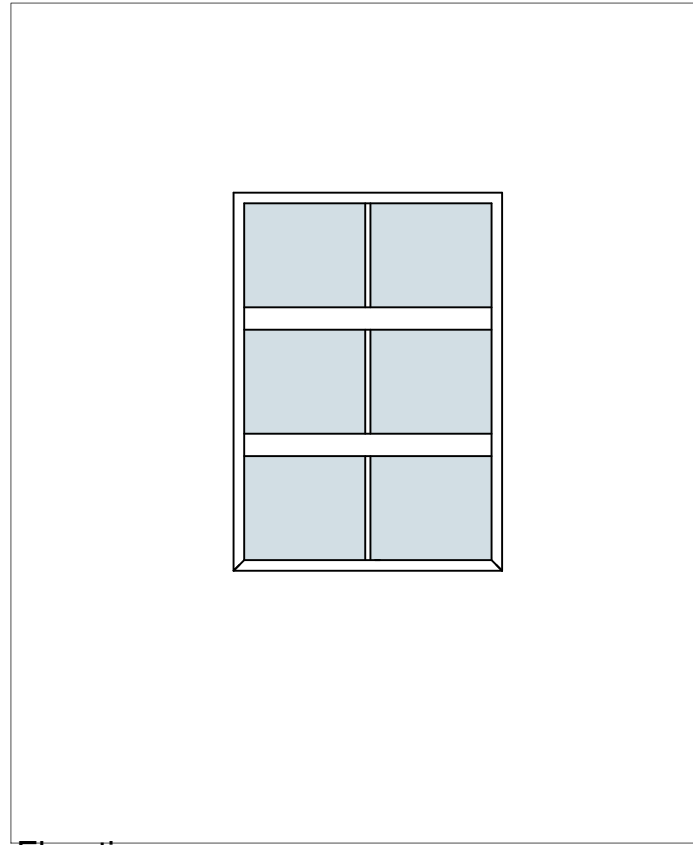

Elevation

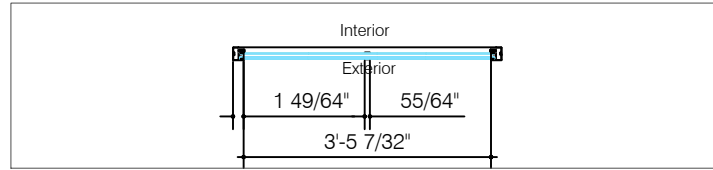

Plan

Glazing Details Windows 3 & 4

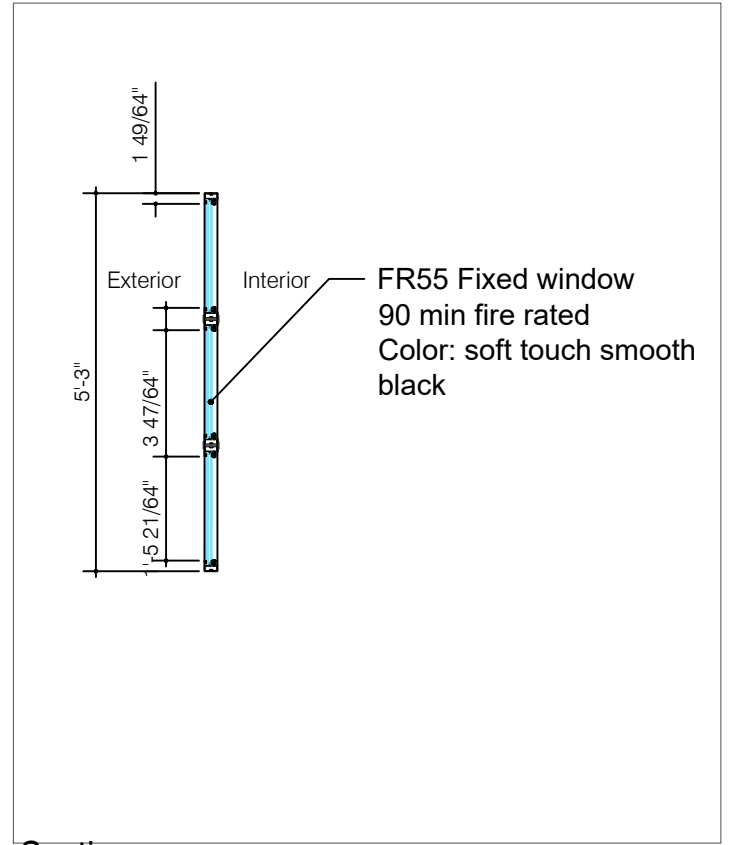

Section

Lower West Window 4

