

42 JANE STREET,
MANHATTAN, NY 10014
BLOCK 625 LOT 33 - DOCKET# LPC-25-07969

Description of the problem:

- We are having **safety, security, and hygiene issues** with **homeless and stranger people** sleeping and leaving stool and dregs on the existing front stair, which gives us access to the main entrance of our home.
- In addition, because we are adjacent to the Jane Street park, strangers often occupy the stairs and smoke pot that wafts through our front door. This happens multiple times per day. These same people often leave food debris, which attracts bugs and rats.

MAP OF APPROVED STOOP GATES IN IMMEDIATE VICINITY

168 Waverly
138 Waverly
122 Waverly Place
17 Barrow Street
79 Christopher St
451 Hudson St
17 Grove St
12-14 Minneta St
133 West 4th Street
132 West 4th Street*

*(Stoop gate existed at the time of designation)



Historic and Existing Property Condition

42 Jane St



HISTORIC PHOTO: 1940



EXISTING CONDITIONS

Historic and Existing Property Condition 42 Jane St



EXISTING CONDITIONS: CLOSE UP

Description of the Work:

- **We want to install a security ornamental iron stoop gate** at the bottom step of the existing front stair of the property as it is shown on elevation drawing (attached on document session)
- **Stoop gate design** follows the existing ironwork alignments and aesthetic design located at front of the property which promotes historic site preservation. With **the stoop gate** we can feel more **secured, cleaner and safer** from homeless or stranger people who is causing us all these worries to our family.

Front Elevation Proposed

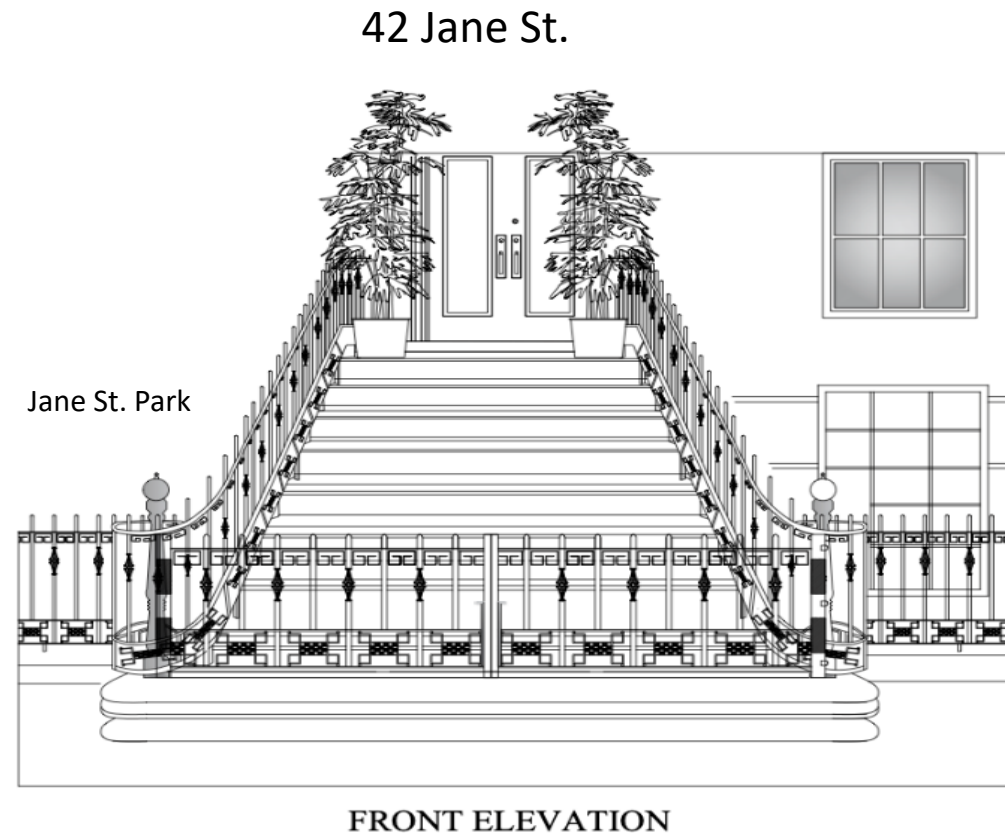

Proposed Gate

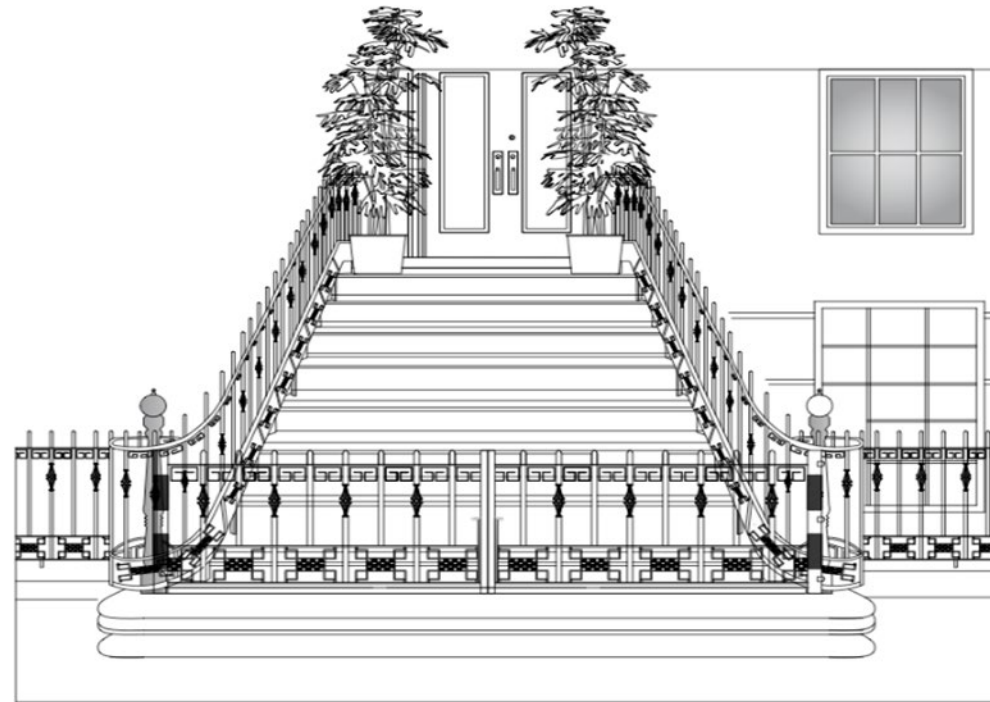

FRONT ELEVATION

Proposed Gate Details

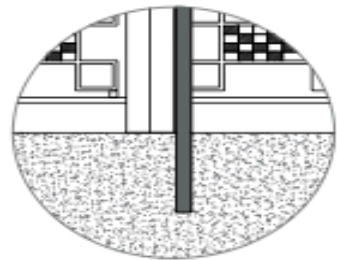
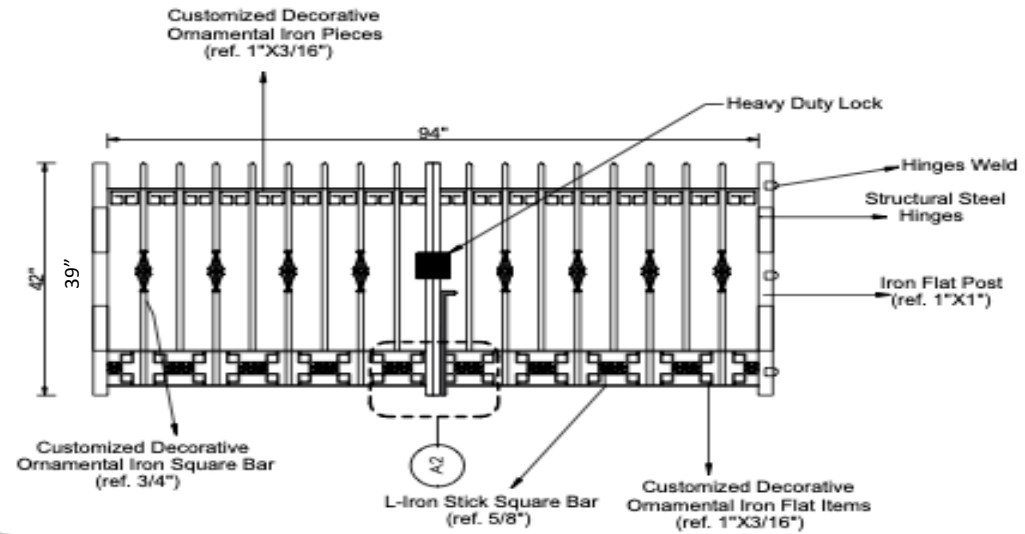

DETAIL A2

Proposed Gate Details

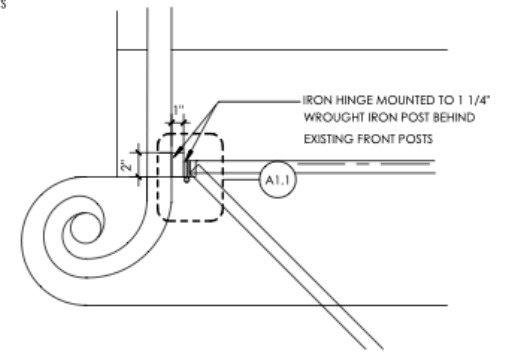
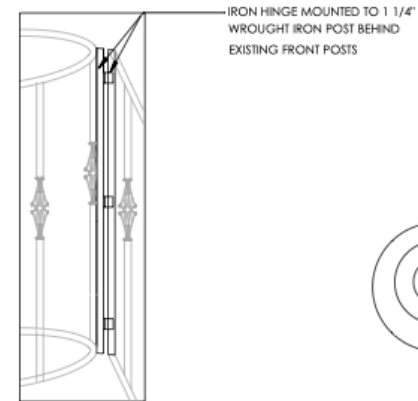
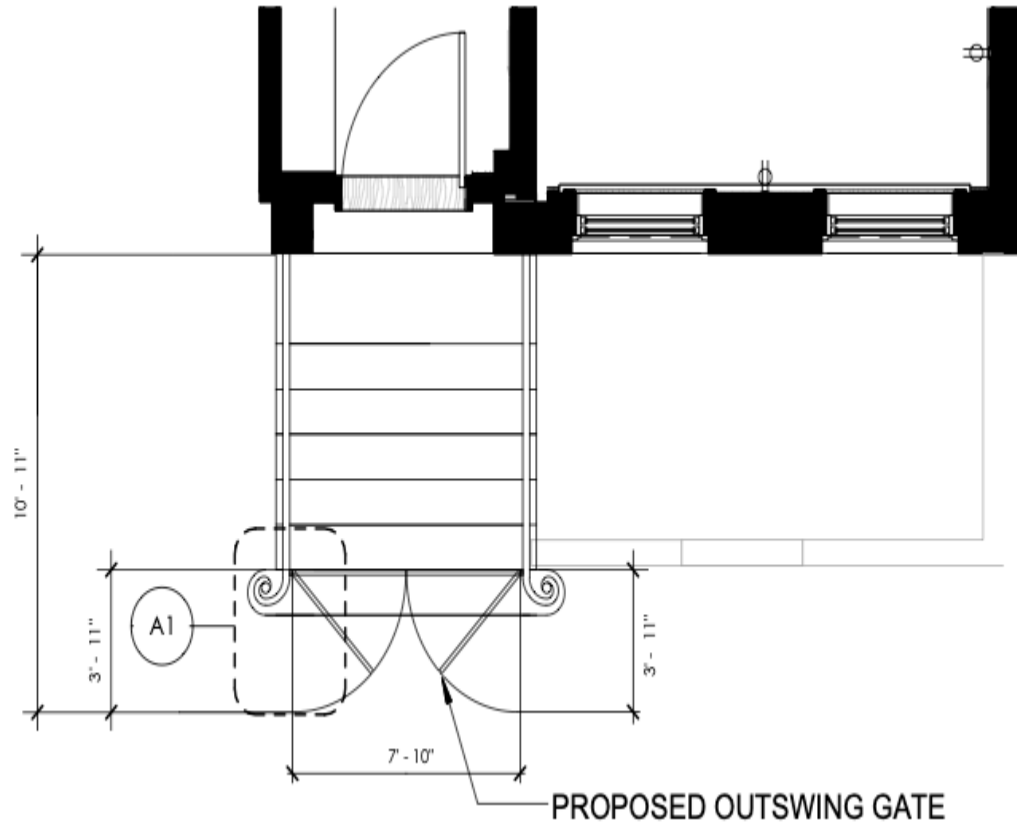

EXAMPLES OF APPROVED STOOP GATES

PHOTOS TAKEN FROM NYC
PROPERTY INFORMATION PORTAL



79 CHRISTOPHER



138 WAVERLY



133 W 4TH



17 GROVE



451 HUDSON



168 WAVERLY